

PARTS LIST

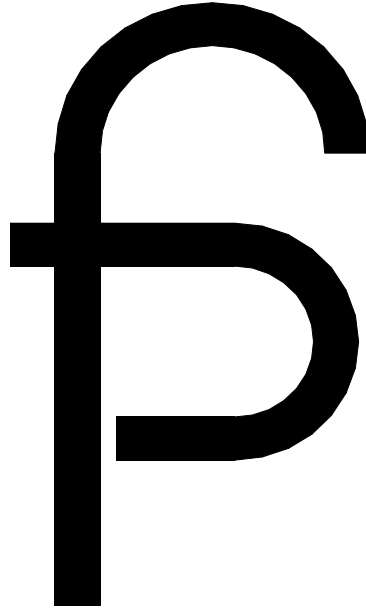

FERTILIZER BOX MODEL FA

Serial Number 2395 - ____

FIRST PRODUCTS INC.
164 Oakridge Church Road
Tifton, Georgia 31794 U.S.A.
Phone 800-363-8780
Georgia (229) 382-4768
Fax (229) 382-0506

Fertilizer Box

(Legend For Pages 1-4)

No.	Order No.	Description	No.	Order No.	Description
1	FA80-015	500 lbs. Box	34	FA27-032	Tube Stabilizer
2	FA27-015	Trough Lock Lip	35		
3	FA50-018	Draw Latch	36		
4	FA50-019	Latch Lock	37		
5	HW41005012SS	5/32" Stainless Rivet (1/4"-3/8" Grip)	38	FA50-049	First Products Decal
6	HW41005008SS	5/32" Stainless Rivet (1/8"-1/4" Grip)	39	HW01012032SSPLC	3/8" x 1" Hex Capscrew Stainless
7	FA80-017	Left Box End Frame	40	HW22012SSPLC	3/8" Flange Lock Nut Stainless
8	FA80-016	Right Box End Frame	41	HW01010024SSPLC	5/16" x 3/4" Hex Capscrew Stainless
9	FB50-077	11/32" Hole Plug	42	HW22010SSPLC	5/16" Flange Lock Nut Stainless
10	FA27-046	Funnel Top, Right	43	FA27-016	Outlet Plug
11	FA27-047	Funnel Top, Left	44	HW01008016SSPLC	1/4" x 1/2" Hex Capscrew Stainless
12	FA24-006	Auger Shaft	45	HW22008SSPLC	1/4" Flange Lock Nut Stainless
13	FB50-034	40 MST Stamping	46	FA27-003	Bulk Head
14	FB50-014	Auger Shaft Bearing	47	FA27-023	Extension End Panel
15	FB50-035	Auger Bearing Seal	48	FA80-021	Extension Front and Rear Panel
16	FB27-009	Seal Plate	49	FA80-020	Extension Corner
17	FA50-017	Feed Wheel	50	FB50-068	First Products Logo Decal
18	FA80-013	11" Left Hand Auger	51	FA80-026	Female Box Connector
19	FA80-014	11" Right Hand Auger	52	FA80-027	Male Box Connector
20	FA80-011	11 3/4" Left Hand Auger	53	FB50-054	1 1/16" Set Collar
21	FA80-012	11 3/4" Right Hand Auger	54	HW40008064SS	1/4" x 2" Cotter Pin
22	FA80-009	Left Hand Auger End Cap	55	FB50-019	Fertilizer Hose (2" Outlet Both Ends)
23	FA80-010	Right Hand Auger End Cap	56	FB50-028	2 1/4" Hose Clamp
24	HW40008048ZP	1/4" x 1 1/2" Cotter Pin	57	FA80-044	S.M.V. Replacement Bracket
25	HW6003204810GPL	1" x 1 1/2" x 10 GA Bushing	58	FA50-051	S.M.V. "U" Bolt
26	HW42008056SS	1/4" x 1 3/4" Roll Pin Stainless	59	HW22010G5ZPC	5/16" Flange Lock Nut
27	HW03008032SSPLC	1/4" x 1" Carriage Bolt Stainless	60	FA50-046	Ground Drive Rate Chart
28	HW22008SSPLC	1/4" Flange Lock Nut Stainless	61	FA50-039	Hydraulic Drive Calibration Instr.
29	FA50-020	Keeper	62	FA80-058	Funnel Adjustment Plate
30	FA80-018	Auger Trough	63	HW01010016SSPLC	5/16" x 1/2" Hex Cap Screw, Stainless
31	FA81-014	Filter Screen	64	FA80-077	750# Extension Bridge
32			65	FA80-065	750# Box Extensions, 36-38" Rows
33	FB50-092	Serial Number Tag	66	FA80-062	750# Box Extensions, 44-48" Rows

***NOTE: ITEMS 20 IS FOR**

**Fertilizer
Box**
(Left End View)

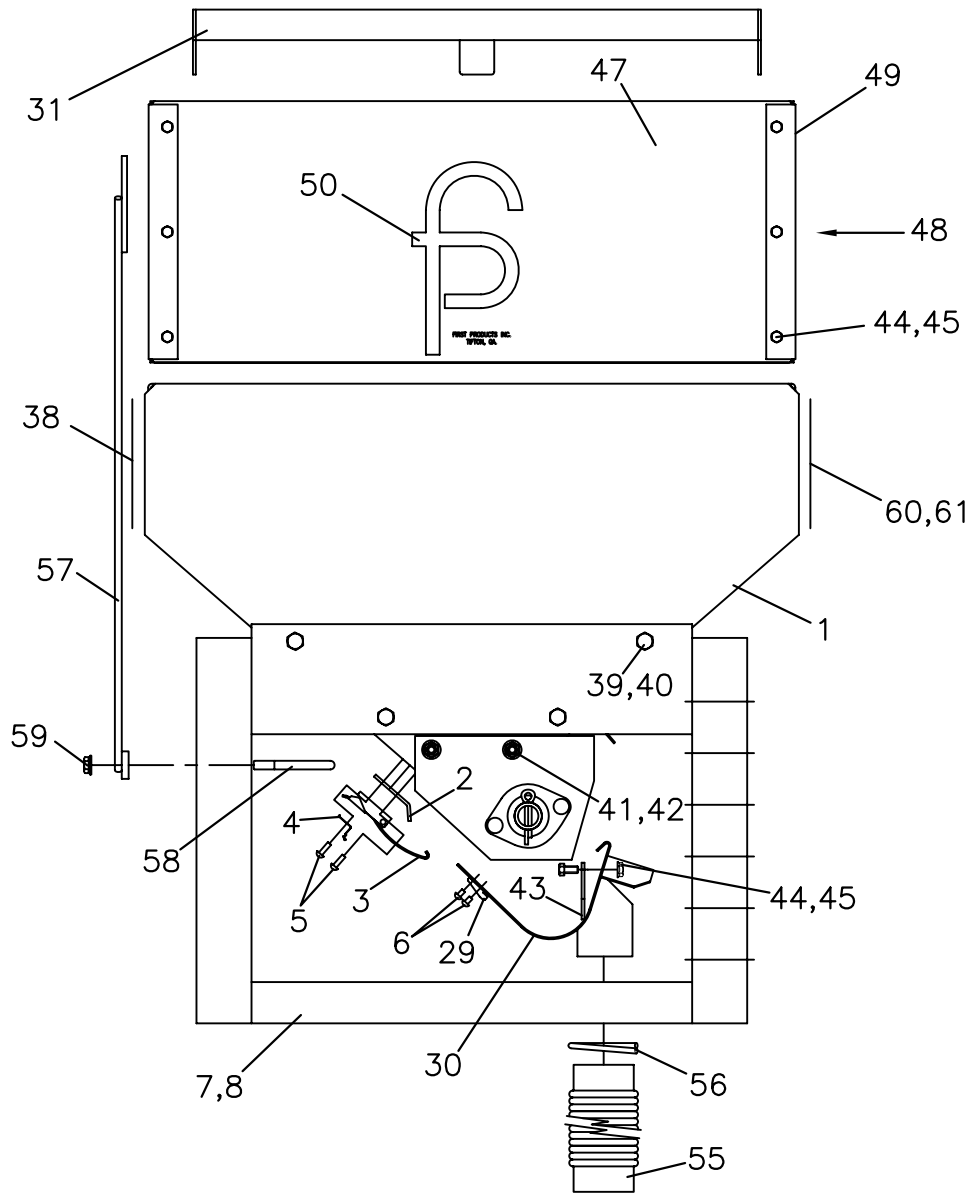

Fertilizer Box

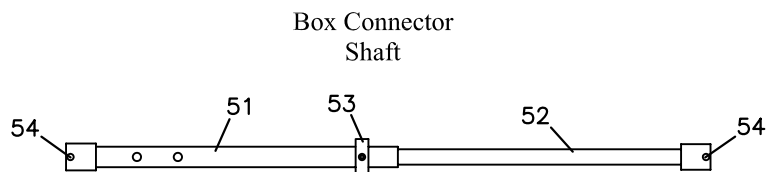
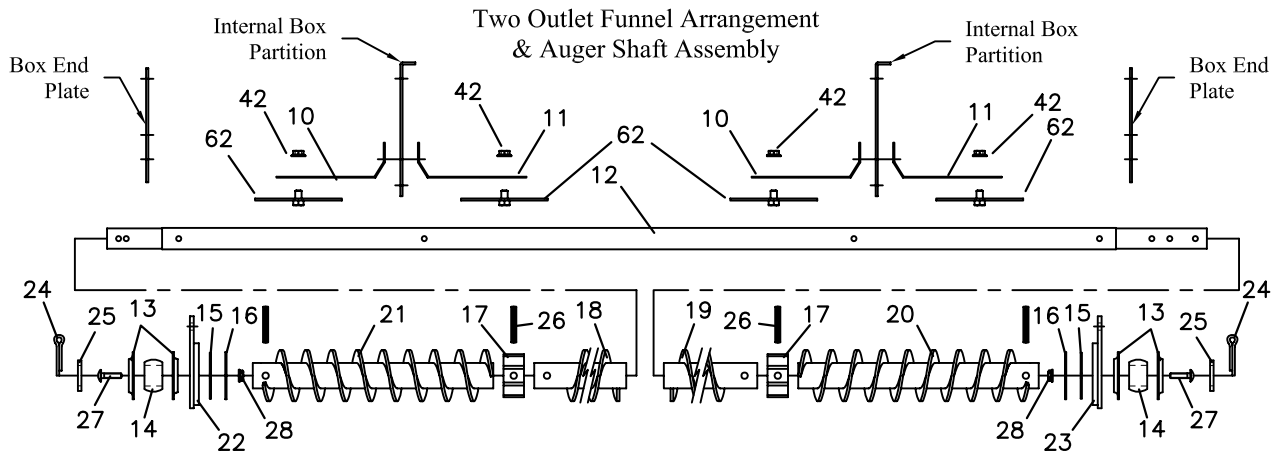
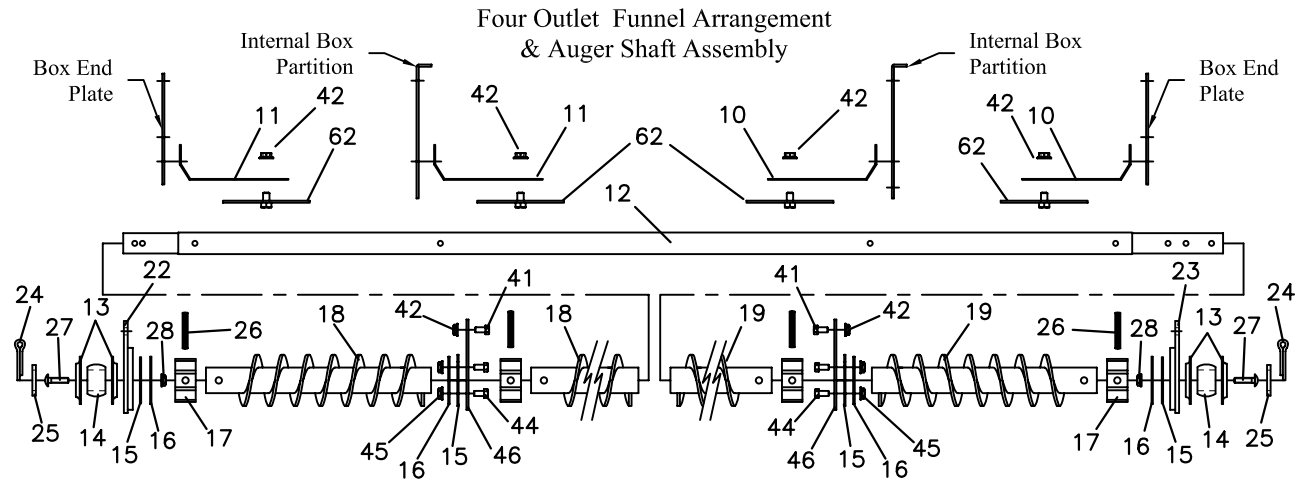

Fertilizer Box

750# Extensions
With Bridge

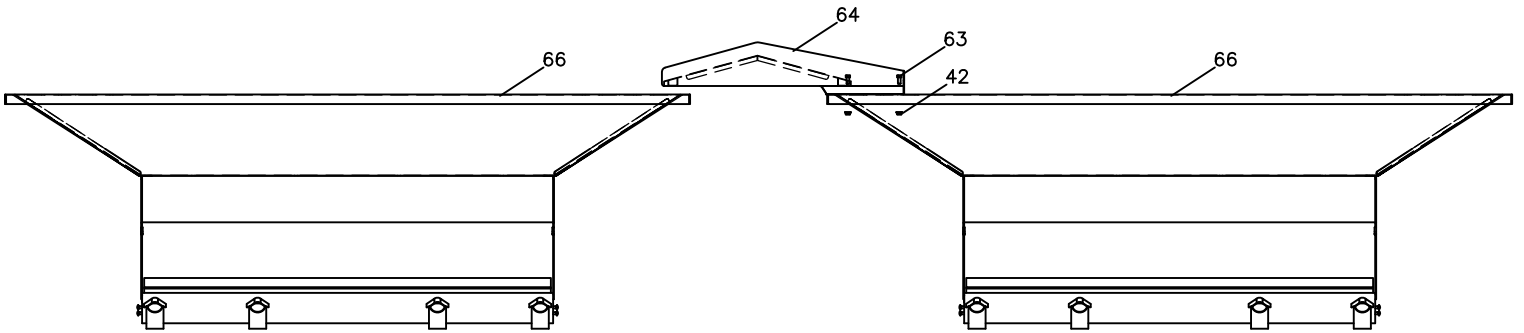
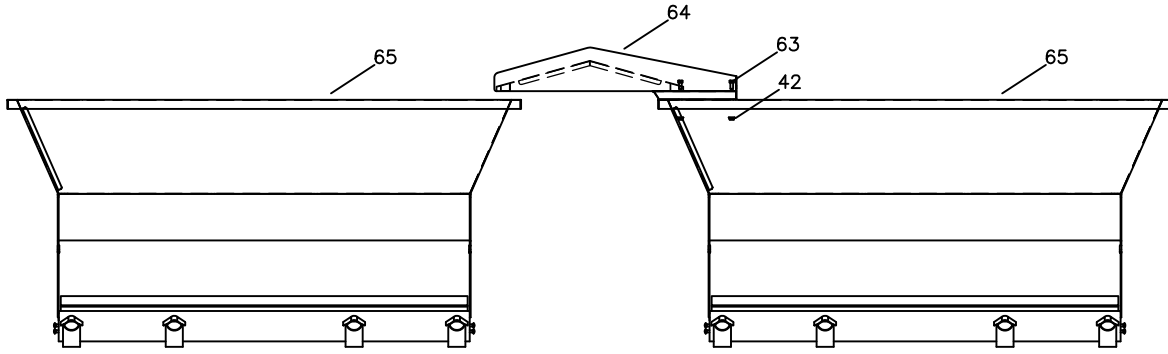

Box Mounts

em No.	Order No.	Description	Item No.	Order No.	Description
1	FA80-006	5/8" Flat Toolbar Clamp	11	HW01020224G5ZPC	5/8" x 7" Hex Capscrew
2	FA27-001	Toolbar To Box Keeper	12	HW01020256G5ZPC	5/8" x 8" Hex Capscrew
3	FA50-011	Toolbar To Box Threaded Rod-12	13	FA80-007	Diamond Clamp
4	HW22020G5ZPC	5/8" Flange Lock Nut	14	FA80-008	Diamond Bracket
5	FA50-050	Toolbar To Box Threaded Rod-14	15	FA23-007	Front Pittsburgh Mount
6	FA80-042	4 3/8" Box Riser	16	FA23-008	Rear Pittsburgh Mount
7	HW01020096G5ZPC	5/8" x 3" Hex Capscrew	17	FA27-002	Pittsburgh To Box Keeper
8	HW30020TAZPC	5/8" Flat Washer	18	HW32020G5ZPC	5/8" Lock Washer
9	HW21020G5ZPC	5/8" Square Nut	19	HW20020G5ZPC	5/8" Hex Nut
10	FA80-043	4" Flat Toolbar Clamp-5/8			

FLAT TOOLBAR MOUNTS

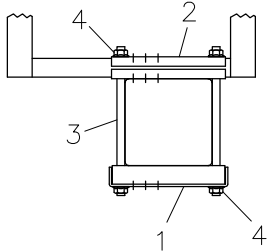

Order No. FA82-004
Flat Toolbar Mounts

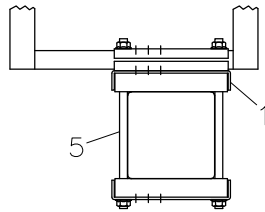

Order No. FA82-015
1 1/16" Box Risers

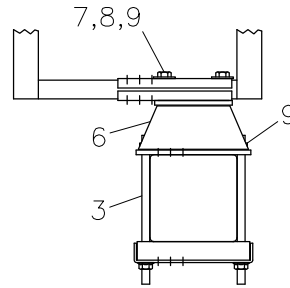

Order No. FA82-014
4 3/8" Box Risers

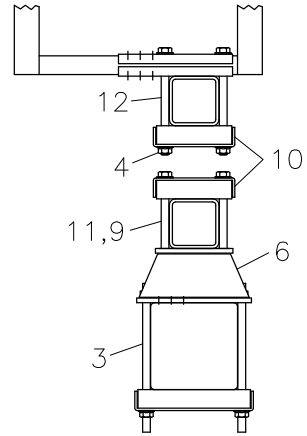

Order No. FA82-016
4" Auxiliary Bar

DIAMOND TOOLBAR MOUNTS

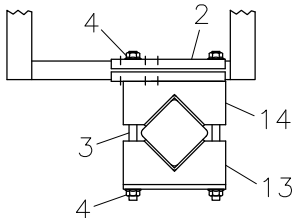

Order No. FA82-005
Diamond Toolbar Mounts

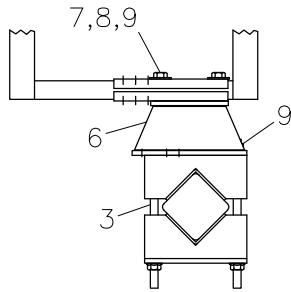

Order No. FA82-014
4 3/8" Box Risers

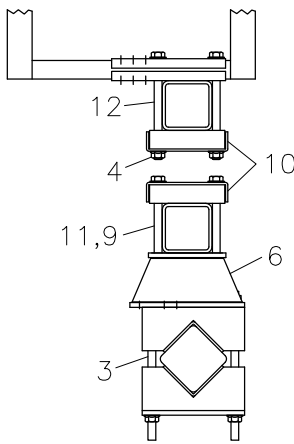

Order No. FA82-016
4" Auxiliary Bar

PITTSBURGH FRAME MOUNTS

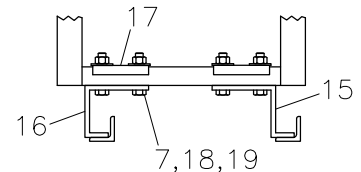

Order No. FA82-006
Pittsburgh Frame Mounts

Hydraulic Drive

Item No.	Order No.	Description	Item No.	Order No.	Description
1	FB80-048	Hydraulic Drive Jackshaft	19	HW22010SSPLC	5/16" Stainless Flange Lock Nut
2	FB50-015	3/4" Acetal Washer	20	HW20012G5ZPC	3/8" HexNut
3	HW6002404010GP	3/4" x 1 1/4" x 10 GA. Machinery Bushing	21	FB50-071	18" Hydraulic Drive Hose
4	HW25024G5ZPC	3/4" Jam Nut	22	HW30012TAZP	3/8" Flat Washer
5	HW50008THD.F	1/4"-28 Grease Fitting	23	FB50-020	Chain Idler
6	FB81-031	72T-15T #35 Sprocket With Bushing	24	FB24-012	Idler Bushing
7	FB50-066	#35 x 80 Pitch Chain	25	HW31016TAZP	1/2" S.A.E. Flat Washer
8	HW01012032G5ZP	3/8" x 1" Hex Capscrew	26	FA80-025	98 Hydraulic Drive Idler Bracket
9	HW3.0012G5ZP	3/8" Lock Washer	27	HW03012072SSPLC	3/8" x 2 1/4" Carriage Bolt
10	FB80-047	15T-15T Sprocket	28	FB50-072	1/2" Ball Valve
11	HW42010040ZP	5/16" x 1 1/4" Roll Pin	29	FB50-073	1/2" x 2 1/2" Nipple
12	HW01008080G5ZP	1/4" x 2 1/2" Hex Capscrew G5	30	FB50-074	1/2" Tee
13	HW22008ZPC	1/4" Flange Lock Nut	31	FB50-075	1/2" Street Elbow
14	FB80-065	Hydraulic Drive Motor Support	32	FB50-062	Flow Control Valve
15	FB80-055	Auger Sprocket 35B72	33	FB50-076	1/2" x 1 1/2" Nipple
16	FB50-082	#35 x 112 Pitch Chain	34	FB50-061	Hydraulic Motor
17	HW40008048BR	1/4" x 1 1/2" Brass Cotter Pin	35	FB50-094	Check Valve
18	HW01010024SSPL	5/16" x 3/4" Stainless Steel Hex Capscrew			

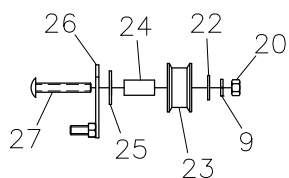
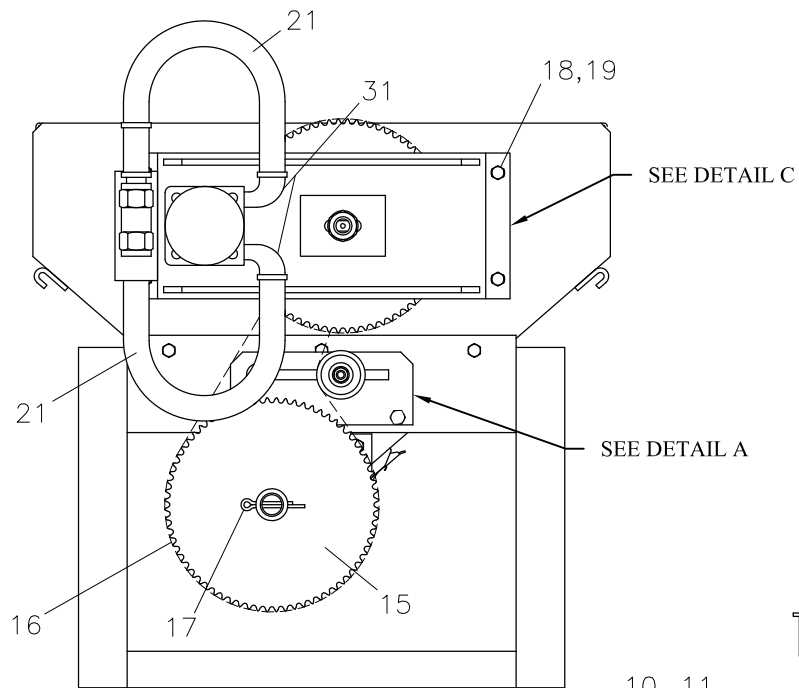

DETAIL A

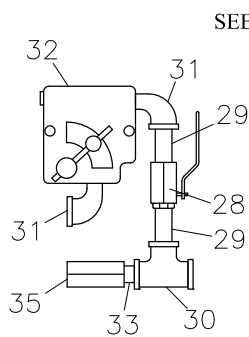

DETAIL B

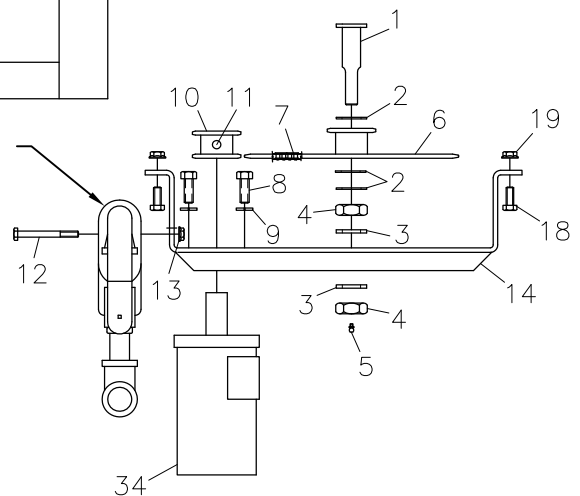

DETAIL C

Ground Drive

(Legend For Pages 7-9)

No.	Order No.	Description	No.	Order No.	Description
1	FA80-028	Idler Bracket	41	HW03010024G5ZPC	5/16" x 3/4" Carriage Bolt
2	FA80-029	Vertical Frame Brace	42	HW22010G5ZPC	5/16" Flange Lock Nut
3	FA50-026	#40-14T Idler	43	HW40008048ZP	1/4" x 1 1/2 Cotter Pin
4	FA50-027	Left Torsion Spring	44	HW24016GBZPC	1/2" Stover Lock Nut
5	FA50-028	Right Torsion Spring	45	HW6003204810GPL	1" ID x 1 1/2" OD x 10GA Mach. Bush.
6	FA24-013	Idler Spacer Long	46	HW03016032G5ZPC	1/2" x 1" Carriage Bolt
7	FA24-014	Idler Spacer Short	47	HW32016G5ZPC	1/2" Lock Washer
8	HW01012128G5ZPC	3/8" x 4" Hex Bolt	48	HW20016G5ZPC	1/2" Hex Nut
9	HW01012288G5ZPC	3/8" x 9" Hex Bolt	49	FA80-041	Horizontal Frame
10	HW22012G5ZPC	3/8" Flange Lock Nut	50	FA80-033	Reach Idler Support
11	HW30012TAZP	3/8" Flat Washer	51	FA50-043	48/ #40 x 232 Pitch Chain
12	FA50-034	#40 x 84 Pitch Chain	52	FA50-044	48/ Hanger Chain
13	FA50-029	Idler Tension Spring	53	FA26-013	Chain Glide
14	FA23-016	Spring Arm	54	HW01010080G5ZPC	5/16" x 2 1/2" Hex Capscrew
15	AE50-105	Hanger "S" Hook	55	HW30010TAZP	5/16" Flat Washer
16	FA80-002	#40 Driver Cluster	56	HW01012032G5ZPC	3/8" x 1" Hex Capscrew
17	FA80-003	#40 Driven Cluster	57	HW24012GBZPC	3/8" Stover Lock Nut
18	FA80-004	#40 34T Sprocket	58	FA50-047	Left Idler Control Decal
19	FA80-005	#40 19T Sprocket	59	FA50-048	Right Idler Control Decal
20	FA80-030	Left Vertical Frame, OAL: 31-1/2"	60	FA80-039	Short Horizontal Frame
	FA80-082	Vertical Frame-2010-LT, OAL: 36-1/2"	61	FA80-040	Chain Bracket
21	FA80-031	Right Vertical Frame, , OAL: 31-1/2"	62	FA50-042	12/ #40 x 90 Pitch Chain
	FA80-083	Vertical Frame-2010-RT, OAL: 36-1/2"	63	FA80-022	#40 x 22T Sprocket
22	FB50-086	Rubber Ground Drive Tire	64	FA80-038	2 1/2" Diamond Bracket
23	FA80-024	Wheel Hub	65	FA50-038	1/2" x 3 3/4" x 5 1/8" "V" Bolt
24	HW01016032G5ZPF	1/2" x 1" NF Hex Capscrew	66	FA26-011	Jack Shaft
25	HW26016G5ZPF	1/2" NF Lug Nut	67	FA24-016	Ground Drive Bar
26	FA80-032	Wheel Transmission Idler Support	68	FA80-034	Ground Drive Mounting Bracket
27	FA50-030	Chain Idler	69	FA24-015	Swivel Pin
28	HW31016TAZPC	1/2" SAE Flat Washer	70	FA23-027	Bearing Support
29	HW40004032ZP	1/8" x 1" Cotter Pin	71	HW03012024G5ZPC	3/8" x 3/4" Carriage Bolt
30	AE50-013	52MM x 3 Hole Flange	72	FA80-037	Idler Slide Arm
31	FA50-031	7/8" Hex Bearing	73	FA80-023	#40 x 37T Auger Sprocket
32	FA50-032	Idler Lock Spring	74	FA50-040	1/2" x 3 3/4" x 6 7/8" "V" Bolt
33	FA50-033	Sprocket Spacer	75	HW40008048BR	1/4" x 1 1/2" Brass Cotter Pin
34	FA50-035	#40 x 98 Pitch Chain	76	FA80-001	Jack Shaft Extension
35	FA26-007	Wheel Shaft	77	HW07012024PLC	3/8" x 3/4" Square Head Setscrew
36	FA26-008	Transmission Input Shaft	78	HW24010GBZPC	5/16 Stover Lock Nut
37	FA26-009	Transmission Output Shaft	79	HW01010024G5ZPC	5/16 x 3/4 Hex Head Cap Screw
38	AE50-149	1/4" Lynch Pin	80	FA27-109	Idler Stop
39	HW01012024G5ZPC	3/8" x 3/4" Hex Capscrew	81	FA50-089	#40 X 118P CHAIN
40	HW06010024G5ZPC	5/16" x 3/4" Flange Locking Screw			

NOTE: ITEM "34" IS USED WITH VERTICAL FRAME OF 31-1/2 OAL, & ITEM "81" IS USED WITH VERTICAL FRAME OF 36-1/2 OAL.

GROUND DRIVE

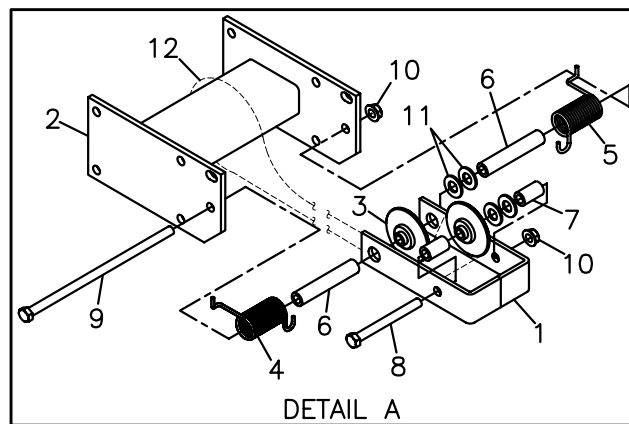
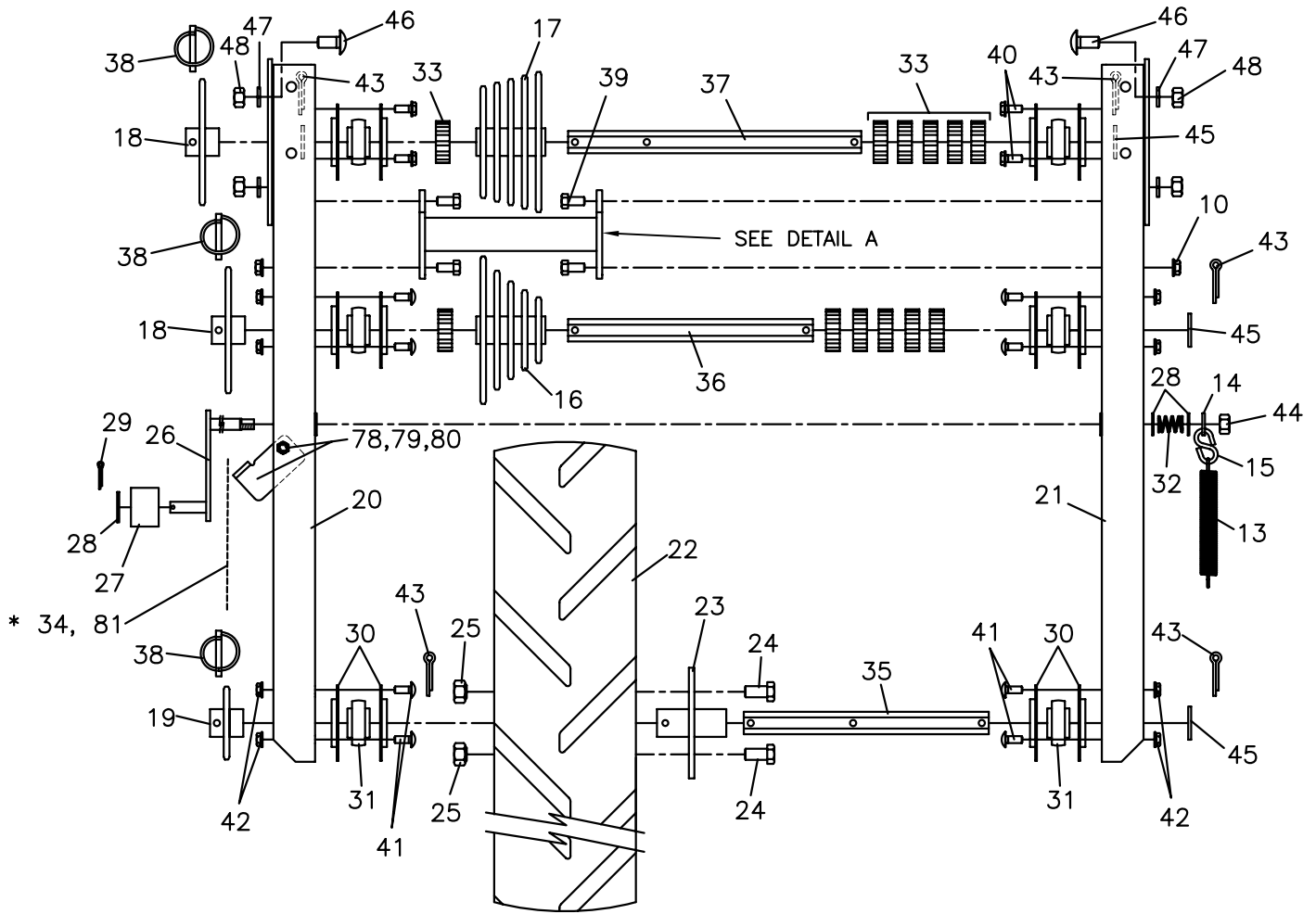

TOOLBAR COMPONENTS

ITEM	PART NO	DESCRIPTION	ITEM	PART NO	DESCRIPTION
1	85-054-27	GAUGE WHEEL MOUNT	25	FA80-054	JACK STAND
2	AE50-156	BRIDGE PIN	26	FA80-055	GAUGE WHEEL POST
3	AG26-003	STAND PIN	27	FB50-019	FERT. HOSE 2" OUTLET BOTH ENDS
4	FA23-052	HOSE BRACKET	28	FB50-028	2 1/4" HOSE CLAMP
5	FA23-058	BRACKET PLATE	29	FB50-091	3/4 X 7 13/16 X 8 3/4 U BOLT
6	FA23-060	HOSE BRACKET, BOX MOUNT	30	FB80-025	GANG HOSE PIPE
7	FA26-016	PIVOT PIN	31	HW01016096G5ZPC	1/2 x 3 HHCS
8	FA27-128	PIN CAP, 1-1/2	32	HW01016160G5ZPC	1/2 X 5 HEX CAPSCREW GD 5
9	FA50-056	DRIVELINE W/1" YOKE	33	HW01020040G2ZPC	5/8 X 1 1/4 HEX CAPSCREW
10	FA50-057	SPINDEL, 2500 LB	34	HW20012G5ZPC	3/8 HEX NUT
11	FA50-058	3/8" U-BOLT, 7 x 7 TOOLBAR	35	HW20016G5ZPC	1/2 HEX NUT
12	FA50-060	STEP LIFT PIN	36	HW20024G5ZPC	3/4 HEX NUT
13	FA50-061	SPACER, CAT. III	37	HW22012G5ZPC	3/8 FLANGE LOCK NUT
14	FA50-065	CYLINDER, 3"x24"	38	HW24016GBZPC	1/2 STOVER LOCK NUT
15	FA50-073	HYD HOSE, 3/8 MP x 48	39	HW26016G5ZPF	1/2 LUG NUT
16	FA50-074	HYD HOSE, 3/8 MP x 72	40	HW32012G5ZP	3/8 LOCKWASHER
17	FA50-086	HYD HOSE, 3/8 MP x 96	41	HW32016G5ZP	1/2 LOCKWASHER
18	FA50-088	WHEEL ASSM.	42	HW32020G8ZP	5/8 LOCKWASHER GD 8
19	FA50-098	1 3/8 TAPER ROLLER BEARING	43	HW32024G5ZP	3/4 LOCKWASHER
20	FA50-099	1 1/4 TAPER ROLLER BEARING	44	HW40005048ZP	5/32 X 1 1/2 COTTER PIN
21	FA50-100	5 X 5 1/2 HUB	45	HW40008080ZP	1/4 x 2 1/2 COTTER PIN
22	FA50-101	1 3/4 X 69mm SEAL	46	HW6002405607GPL	3/4 X 1 3/4 X 7 GA M.B.
23	FA50-102	2 7/16 DUST CAP	47	HW70024G5PLF	3/4 CASTLE NUT
24	FA80-053	7" STAND BRACKET	48	SE50-035	HITCH PIN

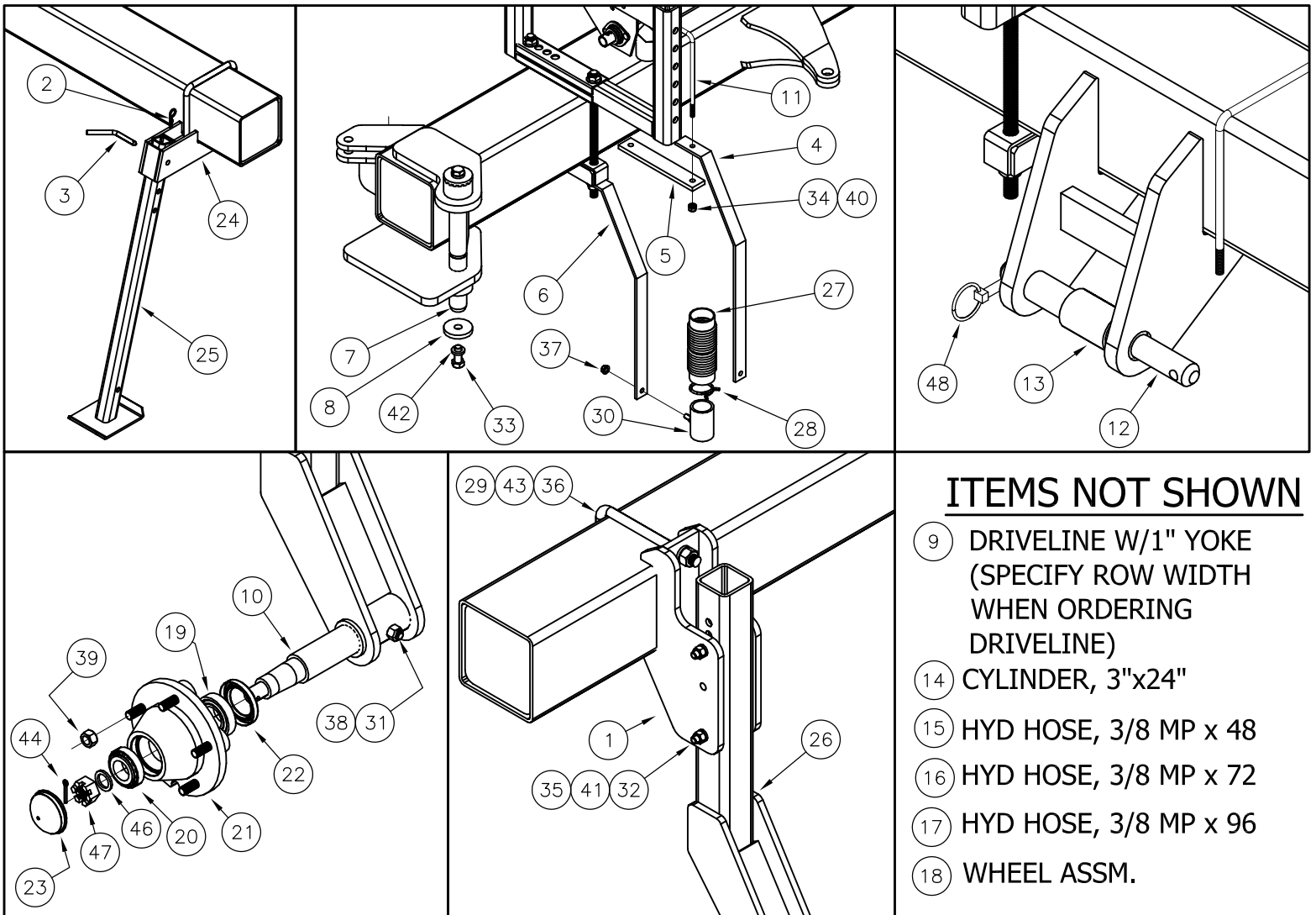

ITEMS NOT SHOWN

- 9 DRIVELINE W/1" YOKE (SPECIFY ROW WIDTH WHEN ORDERING DRIVELINE)
- 14 CYLINDER, 3"x24"
- 15 HYD HOSE, 3/8 MP x 48
- 16 HYD HOSE, 3/8 MP x 72
- 17 HYD HOSE, 3/8 MP x 96
- 18 WHEEL ASSM.

Installation Dimensions

Ground Drive Model/Hyd. Drive Model

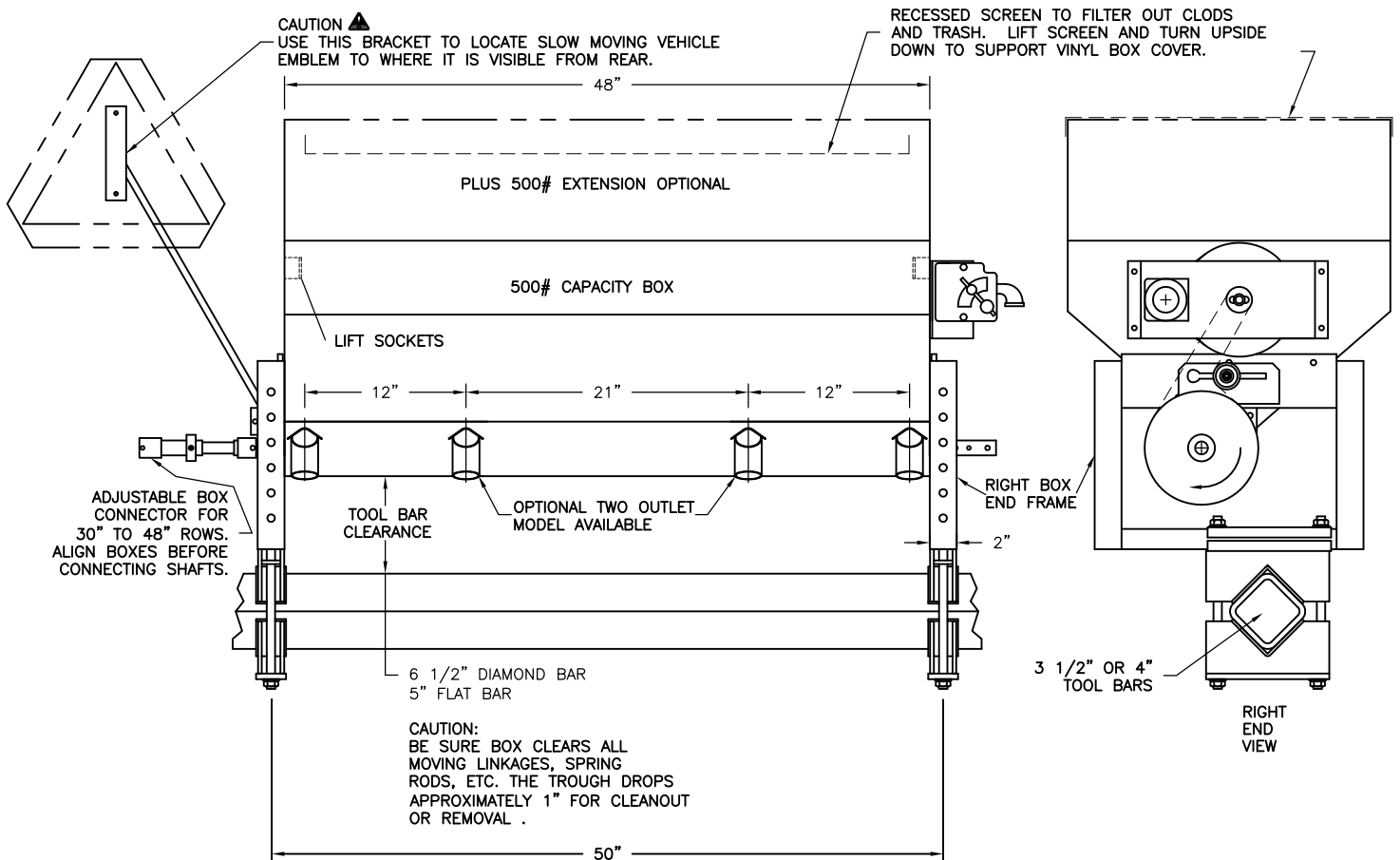
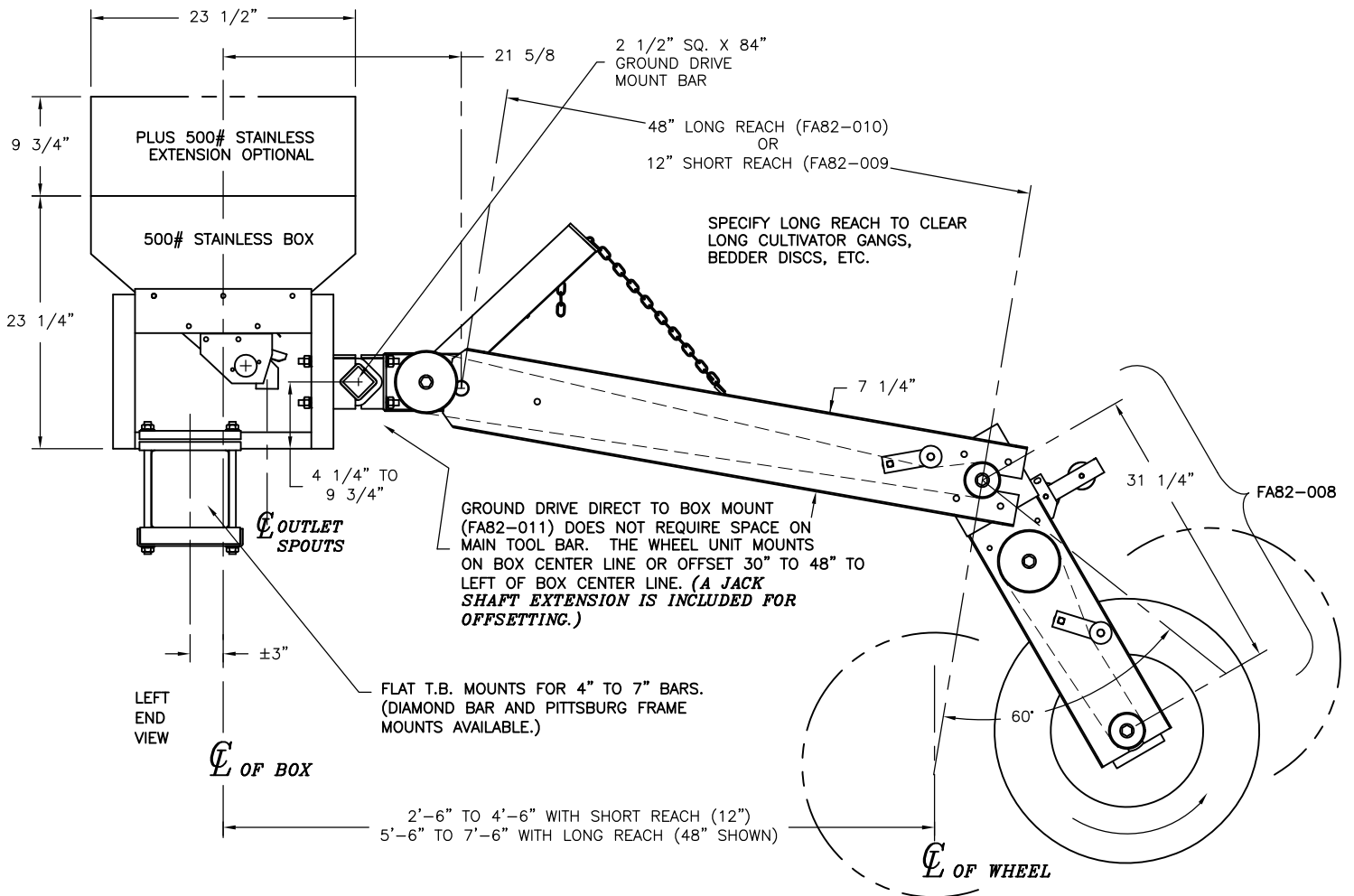

Installation Dimensions

750# Box Extensions

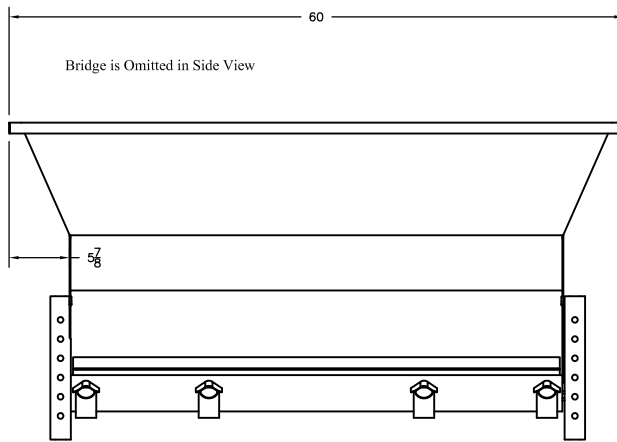
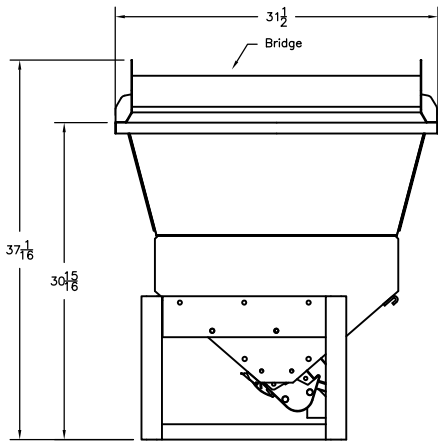

750# Extensions, 36-38" Rows

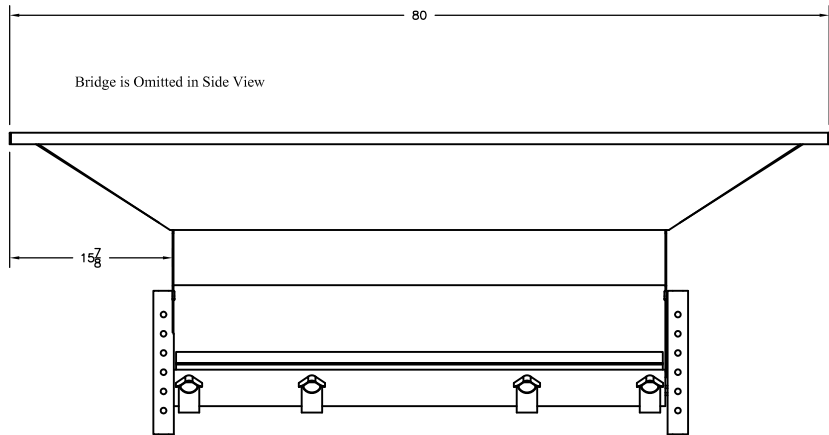
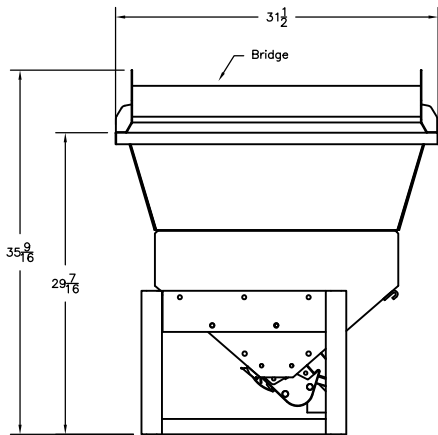

750# Extensions, 44-48" Rows

4" Auxiliary Bar Mount Bracket FA82-016 One Required Per Box

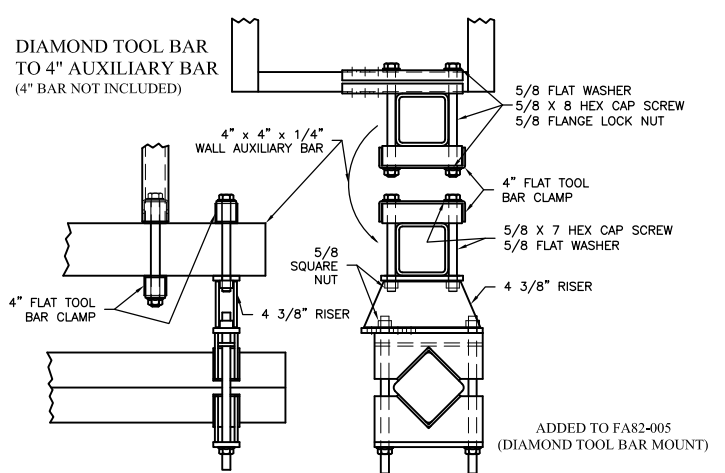
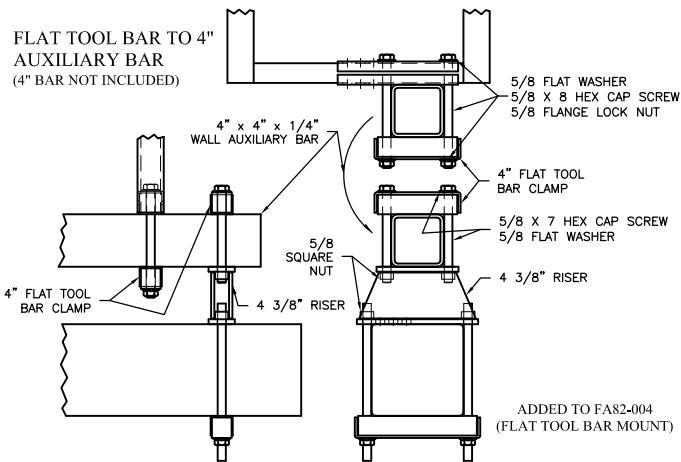

GROUND DRIVE RATE CHART

RATE CHART IS BASED ON GRANULAR MATERIL WEIGHING 80 POUNDS PER CUBIC FOOT
(OR 53.5 POUNDS PER 5 GALLONS) SEE DIRECTIONS FOR MATERIAL WEIGHT ADJUSTMENT TO CHART.

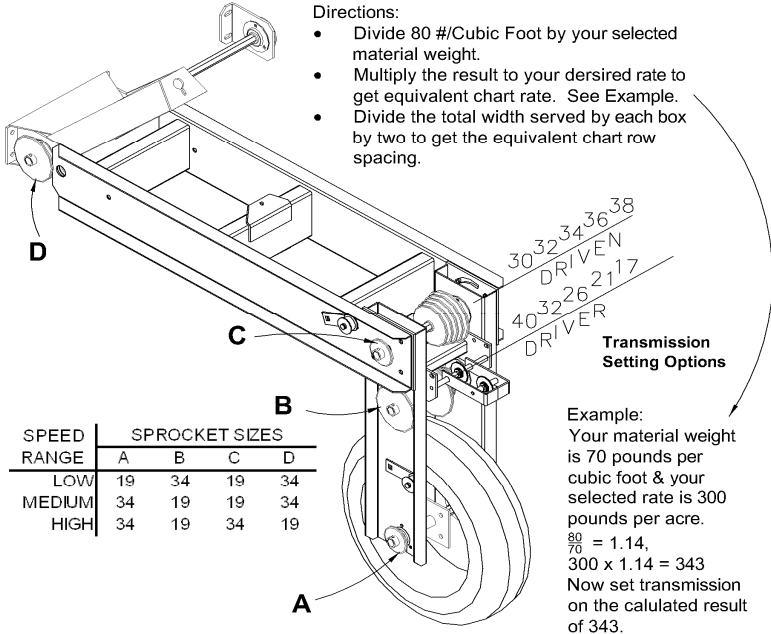

SPEED RANGE	SPROCKET SIZES			
	A	B	C	D
LOW	19	34	19	34
MEDIUM	34	19	19	34
HIGH	34	19	34	19

TRANSMISSION SETTING		LOW RANGE ROW SPACING							
DRIVER	DRIVEN	30	32	34	36	38	40	44	48
17:	38	86	81	76	72	68	65	59	54
	36	91	86	80	76	72	68	62	57
	34	97	91	86	81	77	73	66	61
	32	102	96	90	85	81	77	70	64
	30	108	101	95	90	85	81	74	68
21:	38	103	97	91	86	81	77	70	65
	36	109	102	96	91	86	82	74	68
	34	115	108	102	96	91	86	79	72
	32	122	115	108	102	97	92	83	77
	30	128	120	113	107	101	96	88	80
26:	38	132	124	116	110	104	99	90	83
	36	139	131	123	116	110	104	95	87
	34	146	137	129	122	116	110	100	92
	32	154	144	136	128	121	115	105	96
	30	161	151	142	134	127	121	110	101
32:	38	156	146	138	130	123	117	106	98
	36	166	155	146	138	131	124	113	104
	34	175	164	155	146	138	131	119	110
	32	185	173	163	154	146	139	126	116
	30	194	182	172	162	153	146	133	122
40:	38	186	174	164	155	147	140	127	116
	36	199	187	176	166	157	149	136	125
	34	212	199	187	177	168	159	145	133
	32	226	212	199	188	178	169	154	141
	30	239	224	211	199	189	179	163	149

TRANSMISSION SETTING		MEDIUM RANGE ROW SPACING								HIGH RANGE ROW SPACING							
DRIVER	DRIVEN	30	32	34	36	38	40	44	48	30	32	34	36	38	40	44	48
17:	38	259	243	229	216	205	194	177	162	702	658	619	585	554	527	479	439
	36	272	255	240	227	215	204	186	170	748	701	660	623	590	561	510	467
	34	287	269	253	239	226	215	196	179	793	744	700	661	626	595	541	496
	32	300	281	265	250	237	225	205	188	839	786	740	699	662	629	572	524
	30	314	295	277	262	248	236	214	197	884	829	780	737	698	663	603	553
21:	38	304	285	268	253	240	228	207	190	839	786	740	699	662	629	572	524
	36	322	302	284	268	254	241	219	201	895	839	790	746	707	671	610	560
	34	338	317	299	282	267	254	231	212	952	892	840	793	751	714	649	595
	32	356	334	314	297	281	267	243	223	1008	945	889	840	796	756	687	630
	30	374	351	330	312	296	281	255	234	1064	998	939	887	840	798	726	665
26:	38	353	331	311	294	279	265	241	221	1073	1006	947	894	847	805	731	671
	36	374	351	330	312	296	281	255	234	1142	1071	1008	952	902	857	779	714
	34	396	371	349	330	313	297	270	248	1212	1136	1069	1010	957	909	826	758
	32	418	392	368	348	330	313	285	261	1282	1202	1131	1068	1012	961	874	801
	30	439	412	388	366	347	329	299	275	1351	1267	1192	1126	1067	1013	921	845
32:	38	434	407	383	362	343	326	296	272	1284	1204	1133	1070	1014	963	875	803
	36	460	431	406	383	363	345	313	287	1369	1284	1208	1141	1081	1027	934	856
	34	485	455	428	404	383	364	331	303	1454	1364	1283	1212	1148	1091	992	909
	32	511	479	451	426	404	383	349	320	1540	1443	1358	1283	1215	1155	1050	962
	30	536	503	473	447	423	402	366	335	1625	1523	1434	1354	1283	1219	1108	1016
40:	38	518	486	457	432	409	389	353	324	1704	1598	1504	1420	1345	1278	1162	1065
	36	550	515	485	458	434	412	375	344	1812	1699	1599	1510	1431	1359	1235	1133
	34	582	546	514	485	459	437	397	364	1920	1800	1694	1600	1516	1440	1309	1200
	32	613	575	541	511	484	460	418	383	2028	1901	1789	1690	1601	1521	1383	1268
	30	646	605	570	538	510	484	440	404	2136	2003	1885	1780	1686	1602	1456	1335

HYDRAULIC DRIVE – CALIBRATION INSTRUCTIONS

NOTE: Divide the total width served by each box by two to get the equivalent chart row spacing.

1. Select the desired output rate (lbs./acre)
2. Based on your row spacing and (lbs./acre) use the following table to assemble the auger drive chain for the correct range setting:

ROW SPACING	LOW RANGE		HIGH RANGE	
	Min.	Max.	Min.	Max.
30	72	468	324	2190
32	68	439	304	2053
34	64	413	286	1932
36	60	390	270	1825
38	57	369	256	1729
40	54	351	243	1643
42	51	334	231	1564
44	49	319	221	1493
46	47	305	211	1428
48	45	293	203	1369

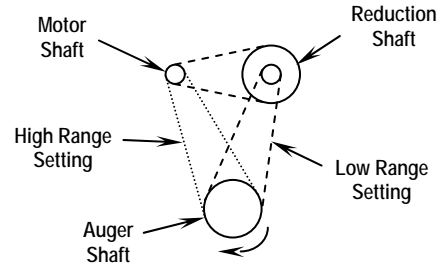

3. Establish the desired tractor ground speed and engine speed.
4. Measure the time (T) required to travel 500ft. at established ground speed.
5. Calculate the pounds to be collected from one box during the time (T) at established engine speed.

$$\text{lbs. (P)} = \frac{\text{lbs./acre} \times \text{row width} \times \text{no. of rows served per box}}{1045}$$

6. Vary the flow control valve handle on the unit to collect lbs. (P) from one box during the time (T) at established engine speed and lock in position. (Do not vary any hydraulic speed controls on the tractor once the unit speed control handle is locked.)

CAUTION: Do not operate the unit with a reduction shaft speed in excess of 160 RPM.
Wash box thoroughly after each application. Lightly oil chains prior to storage.

Determining actual output rate of box.

R = Row spacing = 38"
L = Distance traveled = 500 feet
FR = Desired rate per Acre = 225 lb/acre
PC = Pounds Collected = 15.05 pounds

D = Diameter of Bucket = 11 ¼"
BL = Depth of Bucket = 14"
CR = Correction Factor

- 1) First determine the weight of fertilizer per cubic foot. Example: Using a 5 gallon pail.
 - a) Weigh the bucket empty = 2 pound
 - b) Determine the Volume of the bucket being used:
 - The Diameter (D) and depth of Bucket (BL).
 - The Volume of the bucket: $V = 0.0004 \times D \times D \times BL = 0.00045 \times 11.25 \times 11.25 \times 14 = 0.80$ Cubic Feet.
 - Fill bucket level with fertilizer using, weight = 47.8 pounds, subtract weight of bucket; the weight of fertilizer in bucket is 45.8 pounds.
 - The weight of the Fertilizer per Cubic foot is: 45.8 divide by 0.80 (Volume of pail) = 57.25 pounds per cubic foot.
 - c) Now to determine the start setting of drive using rate charts. Note: The Charts are based on fertilizer weighing 80 pounds per cubic foot.
 - First we will have to determine the correction factor for the Fertilizer: $CR = 80$ divided by (your fertilizer weight) $57.25 = 1.40$
 - Now Multiply the Correction Factor to desired rate FR, $CR \times FR = 1.40 \times 225 = 314$
 - Using the charts, look for the closet setting to 314 and set drive.
 - d) Check actual output catching Fertilizer out of one box.
 - Catch the Fertilizer out each outlet of the box. PC is less Bucket weights.

$$\text{lbs per acre} = \frac{522720 (x) PC}{\text{no. of rows served per box (x)R (x) L}}$$

$$\text{lbs per acre} = \frac{522720 (x) 15.05}{2 (x)38 (x) 500}$$

$$\text{lbs per acre} = 207$$

- To get closer to Desired rate, take 225 divide by 207 = 1.08 and Multiply it to the Previous rate set on drive and re-catch the fertilizer and weigh again. Note: Using Hydraulic Drive, the Engine and Ground Speed must be the same to get correct output per acre. The 500 foot traveled must be the same time each time.