

OPERATOR'S MANUAL & PARTS LIST



MULTI-drill MODEL ND-144

FIRST PRODUCTS INC.
164 Oakridge Church Road
Tifton, Georgia 31794 U.S.A.
Phone (229) 382-4768
1-800-363-8780
Fax (229) 382-0506

Web: www.1stproducts.com Email: Sales@1stproducts.com

ND-144 SER. 1001 thru ____
Printed in U.S.A.
PBREV 0821

INTRODUCTION

Thank you for purchasing a First Products Multi-Drill. This piece of equipment has been carefully engineered and manufactured to provide years of reliable service.

The Multi-Drill is one of the most unique and versatile pieces of equipment on the market today. It is designed for primary seeding in various soil conditions.

We recommend that you carefully read the operators manual prior to operation. Also ensure that all future operators read this manual and become fully trained before allowing them to use or maintain this equipment. Time spent becoming acquainted with the safe operation, performance, and maintenance of the Multi-Drill will add longer life and greater satisfaction to your new purchase.

This machine is designed with safety in mind. However, if the machine is handled carelessly and not as instructed, it can be a dangerous piece of equipment. Observe all safety information in this manual and decals on the equipment.

The illustrations and data used in the manual were current at the time of printing. The manufacturer reserves the right to make changes or add improvements to its products at any time without incurring any obligation to make such changes to products manufactured previously.

For service questions, First Products has trained personnel, genuine First Products parts, and the necessary tools/equipment to handle all your needs.

Use only genuine First Products parts. Substituting parts will void warranty and may not meet standards required for safe and satisfactory operation. Record the model number and serial number of your equipment in the spaces provided below:

MODEL: _____

SERIAL NUMBER: _____

DATE OF PURCHASE: _____

REMEMBER SAFETY IS ALWAYS FIRST!

- **Read and understand the instructions and warnings carefully before using this machine.**
- **Read the warranty located on page 18. Fill in the required information on the warranty registration provided and return to the address on the front of this manual. The warranty registration must be returned to validate warranty.**

TABLE OF CONTENTS

INTRODUCTION	1	After Each Use	17
TABLE OF CONTENTS.....	2	Periodic or Before Extended Storage	17
GENERAL INFORMATION.....	3	WARRANTY INFORMATION	18
SPECIFICATIONS for ND-144	3	Parts Book.....	23
SAFETY SYMBOLS.....	4	Row Unit Group	23
SAFETY RULES.....	5	Spring Rod Group	27
Training	5	Press Wheel Arm Group	28
Preparation	5	Frame Group	29
Operation.....	5	Coulter Shaft Group	33
Transportation	6	Frame to Seeder Group	34
Maintenance	6	Primary Hopper Group.....	37
Storage.....	7	Primary Hopper (Rt) Group	41
SAFETY DECALS.....	7	Agitator Group	45
OPERATION.....	9	Spout Tray Group.....	46
Front Coulter Disc Shaft	10	Hydraulic Idler Group	47
Seed Disc Assembly.....	10	Hydraulic Motor Group.....	48
Seeders	10	Hydraulic Flow Control Group	49
Attaching Multi-Drill	11	Hopper Hydraulics Group	50
1. <i>Standard Cat. II/III 3-point hitch:</i>	11	Auxiliary Hopper Group	52
2. <i>Standard Cat. II Quick hitch:</i>	11	Auxiliary Hopper (Rt) Group.....	56
3. <i>Tow hitch with hydraulics:</i>	11	Auxiliary to Primary Hopper Group	59
Seeder Setup.....	12	Chain Cover Group	60
<i>Seeder Controls</i>	12	Auxiliary Chain Cover Group.....	61
<i>Setting Seed Depth</i>	13	Electrical Group	62
<i>Seeder Calibration</i>	14	Tow Hitch Group	64
CLEANING	17		

GENERAL INFORMATION

The purpose of this manual is to assist you in operating and maintaining your Multi-Drill. Read it carefully. It furnishes information and instructions that will help you achieve years of dependable performance. These instructions have been compiled from extensive field experience and engineering data. Some information may be general in nature due to unknown and varying operating conditions. However, through experience and these instructions, you should be able to develop procedures suitable to your particular situation.

The illustrations and data used in this manual were current at the time of printing, but due to possible inline production changes, your machine may vary slightly in detail. We reserve the right to redesign and change the machines as may be necessary without notification.



Warning

Multi-Drill should never be operated with any safety shielding removed.

Throughout this manual, references are made to right and left locations. These are determined by standing behind the equipment facing the direction of forward travel.

SPECIFICATIONS for ND-144

Working Width	144"
Overall Width	180"
Disc Diameter	Coulter disc: 16" / Seed disc: 13.5"
Disc Spacing	9"
Hitch Category	CAT II/III
Quick Hitch Compatible	Yes
Hydraulic Lift Compatible	No
Towing Hitch Compatible	Yes
Guage Wheels	32 X 11 X 15 (Implement Tire – 20 mph max)
Weight w/ all options	5400 Lbs
Primary Seedbox Capacity	20 Bushels
Auxiliary Seedbox Capacity	7 Bushels
Primary Seed Distribution Method	Gravity metered into rows
Seed Depth Gauge Method	Guage Wheels – Turnbuckle

SAFETY SYMBOLS



ATTENTION! BECOME ALERT! YOUR SAFETY IS INVOLVED!

This is a standard safety alert symbol meaning



CAUTION

Indicates hazardous situation, injury may occur, used to alert against carelessness.



WARNING

Indicates potentially hazardous situation. Death or serious injury may occur if proper procedures are not followed.



DANGER

Indicates most hazardous situation. Death or serious injury will occur if proper procedures are not followed.

SAFETY RULES

Safety is a primary concern in the design and manufacturing of our products. However, our efforts to provide safe equipment can be avoided by an operator's careless act. Accident prevention ultimately is dependent upon the awareness, concern, judgement, and proper training of the personnel involved in the operation, transport, maintenance, and storage of the equipment. It is incumbent upon every operator to practice proper safety protocol to avoid life-threatening situations.

Training

Safety instructions are important! Read all attachment and power unit manuals; follow all safety rules and safety decal information. Failure to follow instructions or safety rules can result in serious injury or death.

If you do not understand any part of this manual and need assistance, call First Products.

Know your controls and how to stop engine and attachment quickly in an emergency.

Operators must be instructed in and be capable of the safe operation of the equipment, its attachments, and all controls. Do not allow anyone to operate this equipment without proper instructions.

Never allow children or untrained persons to operate equipment.

Preparation

Check that all hardware is properly installed. Always tighten to torque chart specifications unless instructed otherwise in this manual.

Always wear relatively tight and belted clothing to avoid getting caught in moving parts. Wear proper personal protective equipment for eyes, hair, hands, hearing, and head.

Make sure all safety decals are installed. Replace if damaged. See Safety Decals

section for location and part numbers for ordering replacements.

A minimum 20% of tractor and equipment weight must be on the tractor's front wheels when attachments are in transport position. Without this weight, front tractor wheels could raise up and result in loss of steering.

Operation

Keep bystanders away from equipment.

Do not operate or transport equipment while under the influence of alcohol or drugs.

Operate only in daylight or good artificial light.

Keep hands, feet, hair, and clothing away from equipment while engine is running. Stay clear of all moving parts.

Always comply with all state and local lighting and marking requirements.

Never allow riders on power unit or attachment.

Power unit must be equipped with ROPS or ROPS cab and seat belt. Keep seat belt securely fastened. Falling off power unit can result in death from being run over or crushed. Keep foldable ROPS system in "locked up" position at all times.

Always sit in power unit seat when operating controls or starting engine.

Securely fasten seat belt, place transmission in neutral, engage brake, and ensure all other controls are disengaged before starting power unit engine.

Look down and to the rear and make sure area is clear before traveling in reverse.

Do not operate seeder in reverse.

Use extreme care when working close to fences, ditches, other obstructions, or on hillsides.

Do not operate or transport on steep slopes.

Do not start, stop, or change directions suddenly on slopes.

Use extreme care and reduce ground speed on slopes and rough terrain.

Watch for hidden hazards on the terrain during operation.

Stop power unit and equipment immediately upon striking an obstruction. Turn off engine, remove key, inspect, and repair any damage before resuming operation.

Transportation

Use additional caution and reduce speed when under adverse surface conditions, turning, or on inclines.

A minimum 20% of tractor and equipment weight must be on the tractor's front wheels when attachments are in transport position. Without this weight, front tractor wheels could raise up and result in loss of steering. The weight may be attained with front wheel weights, ballast in tires, front tractor weights, or front loader. Weigh the tractor and equipment. Do not estimate.

Do not operate or transport on steep slopes.

Always raise unit and install transport lock before transporting. Leak down or failure of mechanical or hydraulic systems can cause equipment to drop.

When utilizing a pull-type hitch, always attach safety chain to tractor drawbar when transporting unit.

Never exceed 20 mph (32.2 km/h) during transport.

Maintenance

Before dismounting power unit or performing any service or maintenance, follow these steps: 1) disengage power to equipment 2) lower unit to ground 3) operate valve levers to release any hydraulic pressure 4) set parking brake 5) stop engine 6) remove key 7) unfasten seat belt.

NEVER GO UNDERNEATH EQUIPMENT. Never place any part of the body underneath equipment or between moveable parts even when the engine has been turned off. Hydraulic system leak-down, hydraulic system failures, mechanical failures, or movement of control levers can cause equipment to drop or rotate unexpectedly resulting in severe injury or death. (Service work does not require going underneath).

Read Operator's Manual for service instructions or have service performed by qualified personnel.

Make sure attachment is properly secured, adjusted, and in good operating condition.

Keep all persons away from operator control area while performing adjustment, service, or maintenance.

Tighten all bolts, nuts, and screws to torque chart specifications. Check that all cotter

pins are installed securely to ensure equipment is in a safe condition before putting unit into service.

Make sure all safety decals are installed. Replace if damaged. See Safety Decals section for location and corresponding part numbers.

Storage

Block equipment securely for storage.

Cover with tarp included with seeder.

Keep children and bystanders away from storage area.

SAFETY DECALS

Your implement comes equipped with all safety labels in place. They were designed to help you safely operate your implement.

1. Read and follow decal directions.
2. Keep all safety decals clean and legible.
3. Replace all damaged or missing decals.
4. Refer to this section for proper decal placement.

Avoid spraying too close to decals when using a pressure washer; high pressure water can enter through very small scratches or under edges of decals causing them to peel or come off.

To install new decals:

Clean the area the decal is to be placed. Peel backing from decal. Press firmly on surface being careful not to cause air bubbles under label.

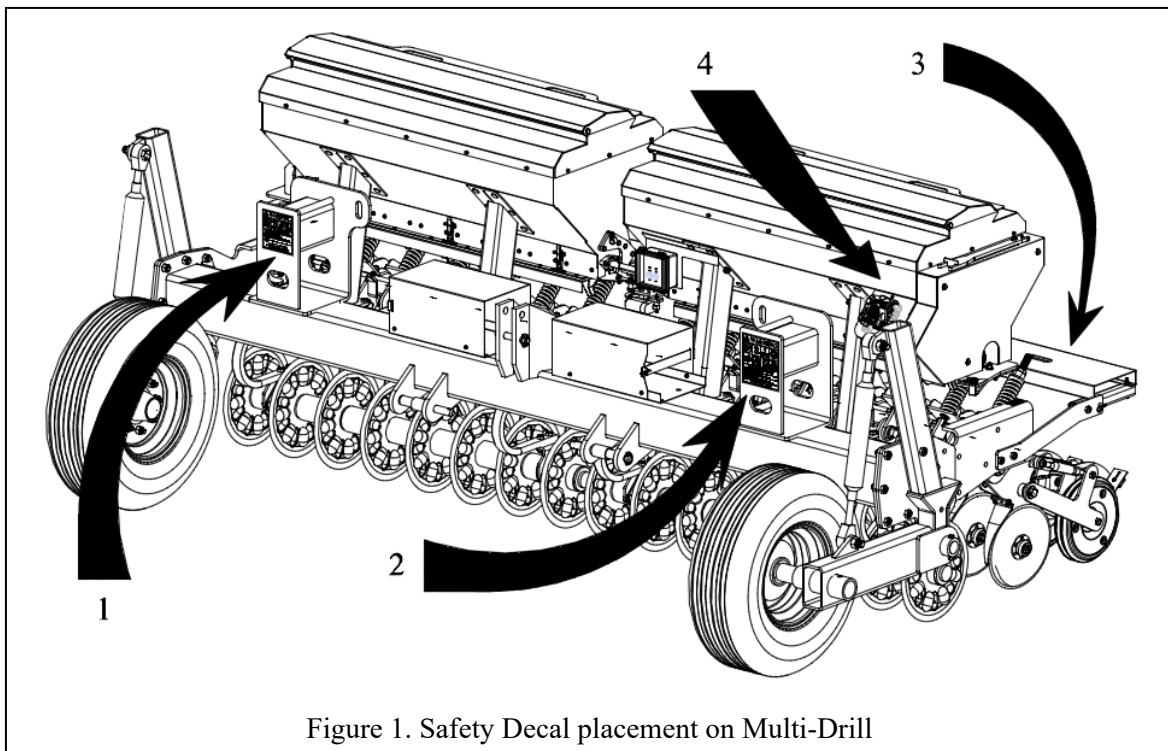

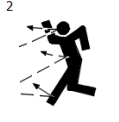
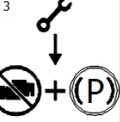
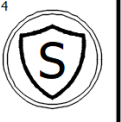



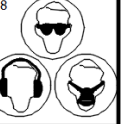



Figure 1. Safety Decal placement on Multi-Drill

⚠ WARNING			
			
CRUSHING AND PINCHING HAZARD			
<ul style="list-style-type: none"> • Be extremely careful handling various parts of the machine. They are heavy and hands, fingers, feet, and other body parts could be crushed or pinched between tractor and implement. • Operate tractor controls from tractor seat only. • Do not stand between tractor and implement when tractor is in gear. • Make sure parking brake is engaged before going between tractor and implement. • Stand clear of machine while in operation or when it is being raised or lowered. 			
FAILURE TO FOLLOW THESE INSTRUCTIONS COULD RESULT IN SERIOUS INJURY OR DEATH.			
<small>DS50-067</small>			

1 – General Warning (DS50-067)

⚠ WARNING			
1 	2 	3 	4 
5 	6 	7 	8 
TO AVOID SERIOUS INJURY OR DEATH:			
<ol style="list-style-type: none"> 1. READ OPERATOR'S MANUAL AND LEARN TO OPERATE SAFELY. 2. KEEP PEOPLE CLEAR WHEN OPERATING. 3. LOWER EQUIPMENT TO GROUND, STOP ENGINE, REMOVE KEY, AND SET BRAKE BEFORE DISMOUNTING TRACTOR. 4. INSTALL AND SECURE ALL GUARDS BEFORE OPERATING. 5. KEEP HANDS, FEET, AND CLOTHING AWAY FROM POWER DRIVEN PARTS. 6. NEVER ALLOW RIDERS. 7. DO NOT TRANSPORT TOWED UNITS OVER 20 MPH. 8. WEAR PROPER SAFETY EQUIPMENT FOR EYES, EARS, AND LUNGS. 			
FAILURE TO FOLLOW THESE INSTRUCTIONS CAN RESULT IN INJURY OR DEATH.			
<small>DS50-068</small>			

2 – Operator Warning (DS50-068)

	⚠ DANGER
<small>AG50-089</small>	DO NOT STAND ON PLATFORM DURING MACHINE OPERATION

3 – No Riders (AG50-089)

⚠ WARNING
KEEP HANDS CLEAR

<small>AE50-194</small>

4 – Hydraulic Pressure (AE50-194)

OPERATION

The operator is responsible for the safe operation of this seeder. The operator must be properly trained. Operators should be familiar with the equipment, the tractor, and all safety practices before starting operation. Read the safety rules and safety decals provided in this operator's manual.

The Multi-Drill is an excellent primary seeder, food plot seeder, and conservation seeder. Its primary function is to deliver a variety of seed to the soil at the desired depth with minimal ground disturbance. The Multi-Drill does this utilizing a series of discs to cut narrow slits in the ground where seed is precisely positioned at the proper depth and packed down via closing wheels. The Multi-Drill is capable of planting multiple seed varieties at once due to its optional second seed box attachment. Seed plates are adjusted on the hoppers to achieve the desired seed rates while electric actuators shuttle the hopper outlets open and closed. When the electric actuators open the hopper outlets, a hydraulic motor powers an agitator shaft which stirs the seed over every outlet to encourage the free flow of seed at the measured rate. The speed of the hydraulic motor can be changed to finetune the seed rate.

WARNING

Power unit must be equipped with Roll Over Protection System (ROPS) or ROPS cab and seat belt. Keep seat belt securely fastened. Falling off power unit can result in death from being run over or crushed. Keep foldable ROPS system in "locked up" position at all times.

Never allow children or untrained persons to operate equipment.

Keep bystanders away from equipment.

Keep hands, feet, hair, and clothing away from equipment while engine is running. Stay clear of all moving parts.

CAUTION

Stop power unit and equipment immediately upon striking an obstruction. Turn off engine, set parking brake, remove key, inspect, and repair any damage before resuming operation.

Always wear relatively tight and belted clothing to avoid getting caught in moving parts.

Wear proper personal protective equipment for eyes, hair, hands, hearing, and head.

Front Coultter Disc Shaft

The Multi-Drill is equipped with a coultter disc shaft mounted to the front of the frame. The function of this shaft is to cut a narrow slit in the ground in preparation for the seed delivery to follow. The cutting depth of the shaft is manipulated using the gauge wheels on the sides of the frame. Whatever the desired depth of the final seed delivery may be, it is recommended that these coultter discs be set to cut ¼” deeper to allow adequate room for the seed to easily fall in and be packed into place. If the ground is too hard for the coultter shaft to reach its target depth, weights can be added to the weight brackets located on both sides of the frame above the coultter disc shaft.

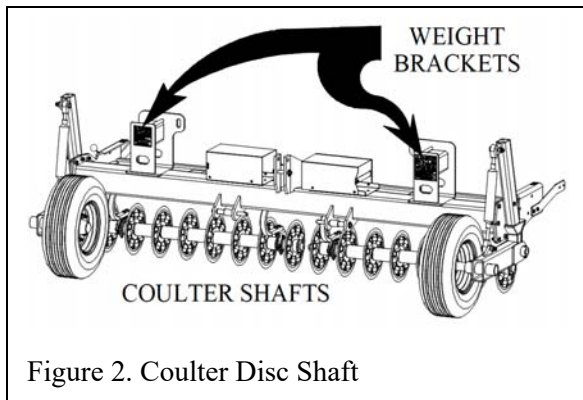

Figure 2. Coultter Disc Shaft

Seed Disc Assembly

Often referred to as double disc openers, the Multi-drill sports offset discs which follow directly behind each coultter disc and are specifically designed to open the slit made by the preceded coultter and drop seed from the primary hopper in the trench made. Each seed disc assembly is comprised of two angled discs, pressure spring, turnbuckle, seed tube, and press wheel. The seed depth is adjusted utilizing the turnbuckle. The seed tube receives the hose from the primary box and drops the seed directly between the discs at the measured depth created by the discs.

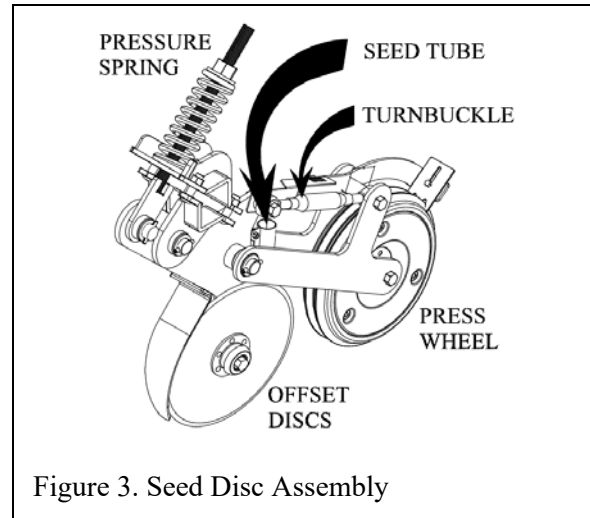

Figure 3. Seed Disc Assembly

The press wheel utilizes the force from the spring to firm up the soil over the seed.

Seeders

The Multi-drill is equipped with a standard hopper, referred to as “primary”, while having the capability of adding a smaller hopper for simultaneous applications. The seeders are comprised of a hopper, seed plates, electric actuator, hydraulic motor, and one handheld control harness. Each seeder utilizes the same metering principle and delivery system. The outlets on the bottom of the seeders have their sizes adjusted manually by sliding the seed plates past one another, Figure 4. There are different sizes of seed plates to account for the various seeds

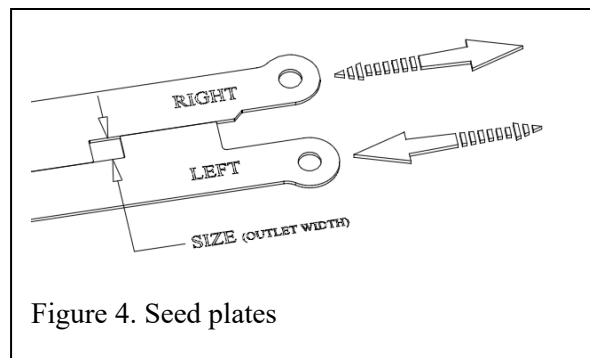

Figure 4. Seed plates

which are specified in the calibration instructions. A handheld control harness tethered to the seeders opens and closes the seed openings using a cutoff plate. When the seeder is energized, an electric actuator opens the bottom of the seeder exposing the outlets while a hydraulic motor powers an agitator

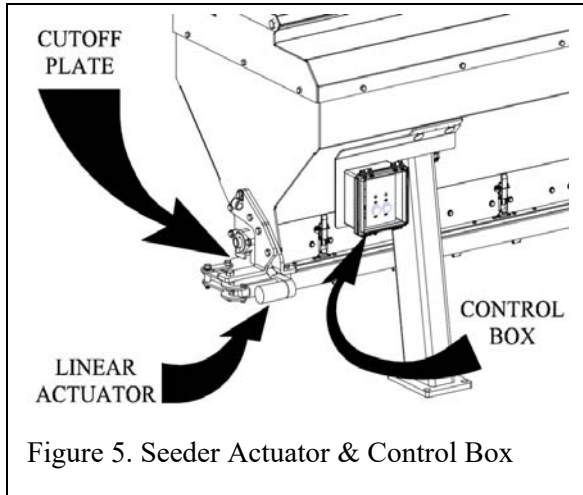

Figure 5. Seeder Actuator & Control Box

shaft which stirs the seed inside the hopper as shown in Figure 5. The speed of the hydraulic motor is adjusted using the flow control valve (discussed further in Seeder Controls section). Figure 6 shows the location of the flow control valve, the hydraulic motor, and the agitator shaft which stirs the seed in the hopper.

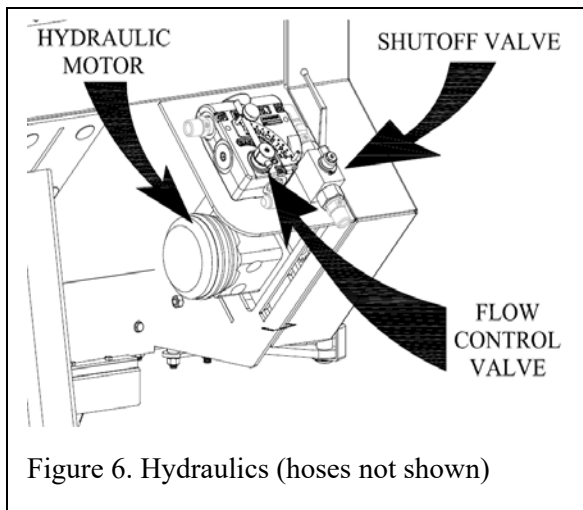

Figure 6. Hydraulics (hoses not shown)

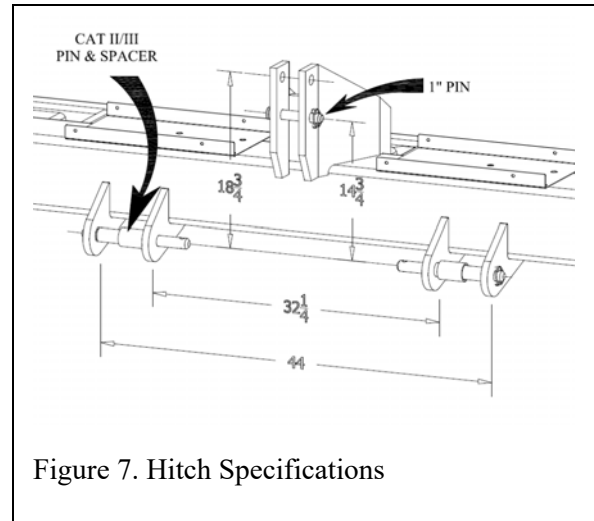

Figure 7. Hitch Specifications

Attaching Multi-Drill

Note: The ND-144 Model is designed to have three ways of attaching to power unit:

1. Standard Cat. II/III 3-point hitch
2. Standard Cat. II Quick hitch
3. Tow hitch with hydraulics

1. Standard Cat. II/III 3-point hitch:

Attach the tractor's lower lift arms to the Multi-Drill's frame and secure with indicated hitch/lynch pins (Figure 7). Attach the tractor's top link to the mast plates of the Multi-Drill.

2. Standard Cat. II Quick hitch:

For quick hitch use, install the bushings with lower lift pins and appropriate top pin to receive upper hook.

3. Tow hitch with hydraulics:

The tow hitch requires hydraulics cylinders to act in place of the turnbuckles which adjust the gauge wheels. Simply pin the tow hitch tongue to the tractor's drawbar and plumb the hydraulics to the tractor's remote ports accordingly.

Seeder Setup

The Multi-Drill is capable of planting a wide variety of seeds over a wide range of seeding rates. Several variables have to be taken into account when planting: seed depth, ground speed, and seed rate. These all have to come together in order to achieve the optimum stand desired.

The Multi-drill seeder utilizes a gravity feed system combined with variable seed agitation and adjustable outlets to achieve consistent and precise seed rates. The size of the outlets is primarily a function of what size seed plate is used during calibration. The speed of the seed agitator is manipulated toward the end of the calibration process to finetune the desired rate.

Seeder Controls

After hitching the Multi-drill to the tractor, the electrical harness and hydraulic hoses must be properly routed and connected.

The electrical connection starts at the tractor's battery where it is then routed to the operator's station and terminated on the seeder's control box seen in Figure 5. This harness includes the lanyard tethering the switch box to the operator. Ensure this wiring harness is clear of any moving parts or obstructions during operation and that the operator can easily access the switch box at all times.

The hydraulic lines are simply plumbed into the tractor's remote ports. If the tractor uses a closed-center system, the shutoff valve located by the flow control valve (Figure 6) will need to be closed allowing the tractor to sense the pressure needed to operate the hydraulic motor. However, if the tractor has an open-center hydraulic system the shutoff valve needs to remain open. The flow control valve is used to adjust the speed of the agitator shaft (Figure 9)

Quick Start Setting Guide						
Model ND-72						
Seed Type	Seed Rate (Lbs/Acre)	Plate Size	Agitator Shaft (rpm)	Ground Speed (mph)	Plate Position	Weight Collected (Lbs/min)
Oats	105	3/4"	32	3	3	3.82
				4	3 2/3	5.10
				5	4 1/3	6.36
Rye	100	1/2"	26	3	2	3.64
				4	2 2/3	4.85
				5	3 1/3	6.06
Rye Grass	25	1/2"	26	3	2	0.91
				4	2 1/3	1.21
				5	2 2/3	1.51
Wheat	100	1/2"	26	3	2 1/3	3.64
				4	2 2/3	4.85
				5	3	6.06
Cow Peas	70	1/2"	26	3	3	2.55
				4	3 2/3	3.39
				5	4 1/3	4.24
Soybean	100	1/2"	26	3	3 1/3	3.64
				4	4	4.85
				5	4 2/3	6.06
Brown Top Millet	20	1/4"	26	3	1 2/3	0.73
				4	2	0.97
				5	2 1/3	1.21
Clover	25	1/4"	26	3	1 2/3	0.91
				4	2	1.21
				5	2 1/3	1.51
Grain Sorghum	25*	1/4"	20	3	1 2/3	0.91
				4	2	1.21
				5	2 1/3	1.51

* Recommended

Figure 8. Quick Start Setting Guide - Step 3

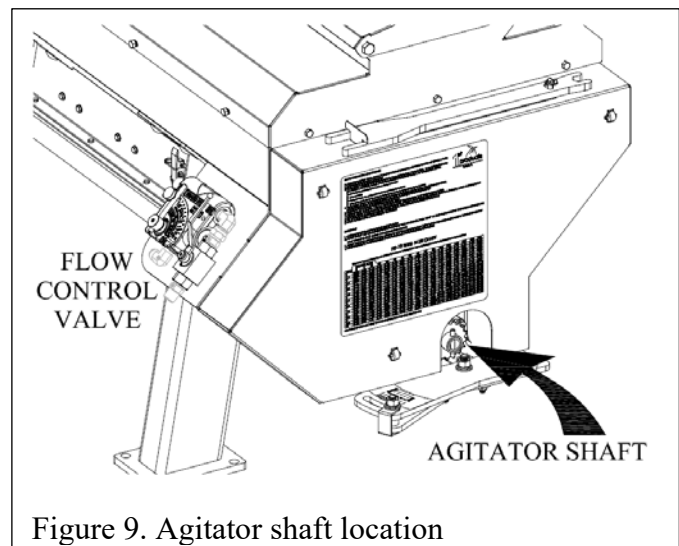

Figure 9. Agitator shaft location

Setting Seed Depth

After hitching Multi-drill and making all necessary connections (see previous sections), the seed depth must be set before seed calibration is addressed. The following steps must be done in order to set the seed depth:

1. Level Multi-drill frame
2. Set Coulter depth
3. Check seed depth and adjust

Each of these steps is detailed below:

1. Level Multi-drill Frame

Whether using the standard 3-point hitch or the towing hitch, the procedure is the same. Lower the Multi-drill to the ground. Pull forward a short distance to allow the coulter discs to settle into the ground. Place a level on the main toolbar of the Multi-drill and check for adjustments (Figure 10). Use the top link to tilt the frame until its operation is level.

2. Set Coulter depth

Using a scale, measure the depth of cut the coulter discs made from the leveling process. The coulter discs are designed to cut $\frac{1}{4}$ " deeper than the desired seed depth. So, if the desired seed depth is $\frac{3}{4}$ ", the coulter discs are to cut 1" deep.

To adjust depth with a 3-point hitch, the machine must be lifted in the air and have each top link on both sides adjusted accordingly, Figure 10. Use a tape measure to ensure they are both the same.

To adjust the depth with a tow hitch, hydraulic cylinder stops are used to limit the stroke of the gauge wheels. With the machine in the air, simply add/remove the stops where the gauge wheel lowers the coulter discs to desired depth ($\frac{1}{4}$ " increments).

3. Check seed depth and adjust

Once the frame is level and the desired depth of cut is obtained, a short pass can be made operating the seeder at the desired speed (wait until seeder calibration is done before filling hoppers). This allows the operator to check the seed depth.

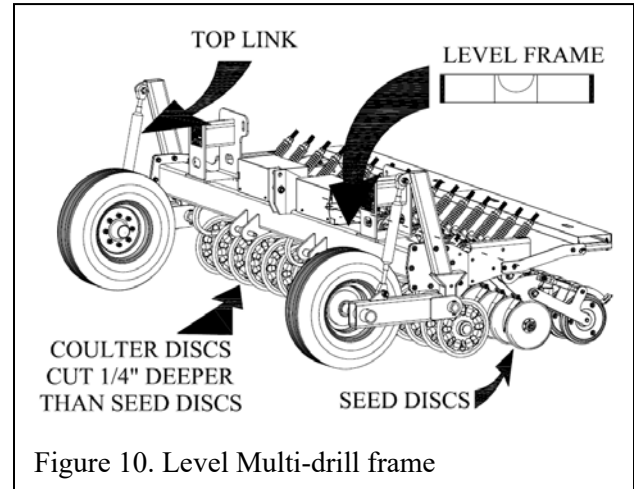

Figure 10. Level Multi-drill frame

After checking the depth of the seed in the ground, changes can be made by adjusting the pressure on the Press Wheel (Figure 11). The seed can be slightly lowered or lifted rotating the Top Link on the attached Row Unit. Shorten the Top Link to lower the seed deeper and lengthen the Top Link to raise the seed closer to the surface. The Scraper Gauge is used as a point of reference for this final adjustment. Simply repeat this step until the proper seed depth is obtained.

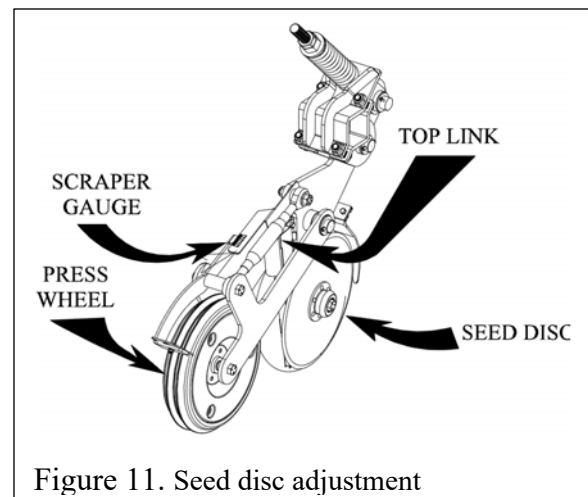

Figure 11. Seed disc adjustment

Seeder Calibration

Before operating the seeder, calibration has to be done in order to take all variables into account and maximize efficiency of the seeder. The following steps must be done to calibrate the seeder:

1. Determine ground speed.
2. Select seed rate.
3. Select seed plates.
4. Use calibration chart to find target seed weight (Figure 13).
5. Position calibration trough to catch seed.
6. Operate seeder in air for 1 minute.
7. Compare weight of seed caught to the target weight in step 4.
8. Manipulate seed plates or electric motor speed to reach target weight.
9. Repeat steps 5 thru 8 until target weight is achieved.
10. Check for consistent seed metering.

Each of these steps is detailed below:

1. Determine ground speed

Determining ground speed usually depends on the terrain in which the seeding is done. In order to help set a ground speed, it is recommended the operator make a test pass without operating the seeder to determine a good starting point. If the tractor isn't equipped with a speedometer, a smartphone app may prove useful.

2. Select seed rate

Most seed varieties have a set standard for what rate works best. Investigate the seed and determine what the recommended rate would be for the particular application. The calibration chart uses pounds per acre.

3. Set seed plates and hydraulic motor setting

Determine the seed plates needed to achieve the desired seed rate. The seed plates come in four different sizes identified with laser etching on one end. Figure 8 displays a Quick Start Setting Guide. This chart is used as a point of reference to help select the proper seed plate, set their

starting position, and choosing the agitator shaft speed.

If the Quick Start Setting Guide is not helpful for selecting a seed plate, below is a list of common seeds under the corresponding seed plates:

¼" Seed Plate: Clover, Grain, Sorghum, Canola

3/8" Seed Plate: Soybeans (**low rates**)

½" Seed Plate: Wheat and Rye Grass Peas, Beans (**under 60 lbs/acre**), Soybeans (**moderate rates**)

¾" Seed Plate: Wheat and Rye Grass, Oats, Mixes, medium to large Grains, Peas, Beans (**over 60 lbs/acre**), Soybeans (**high rates**)

If the current plates inside the hopper are not the desired set to use, refer to "Changing Seed Plates" for step-by-step instructions.

To set the seed plates, the Multi-Drill is supplied with a wrench, DS27-026, to help as shown in Figure 12. Use the wrench to loosen the Setting Bolt sporting the arrow; the wrench also adds leverage for shifting the plates to the desired setting. When the setting is adjusted, retighten the Setting Bolt and store the wrench for future use.

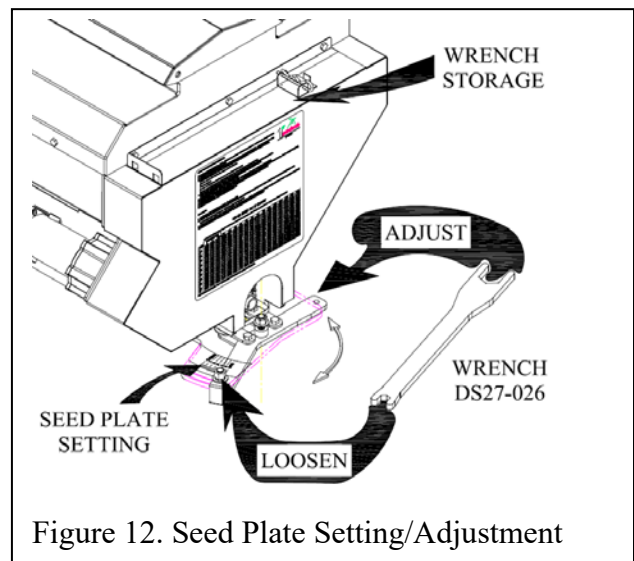

Figure 12. Seed Plate Setting/Adjustment

At this time, the agitator shaft speed should be set to what the Quick Start Setting Guide recommends. Figure 6 illustrates the location of the motor and flow control valve while figure 9 shows the location of the agitator shaft. With speed in mind, the operator must manually adjust the flow to the hydraulic motor in order to achieve the target agitator shaft in revolutions per minute.

4. Find Target Seed Weight

Finding the Target weight is simply done using the calibration chart seen in Figure 13. Knowing the ground speed (left side of chart) and the desired seed rate (top of chart), a target weight to be caught can be selected.

5. Position Calibration Trough

Every Multi-Drill is equipped with calibration trough which is used to catch the seed. In order to do so, the trough should be positioned directly under the seed discs while the machine is lifted.

6. Operate Seeder for One Minute

With seed loaded in Multi-Drill, use the handheld control harness to open the seed plates and energize the hydraulics while the machine in the air for one minute. The seed should flow through

the seed discs and be captured by the calibration trough.

7. Weigh and Compare Seed Weight

The seed caught in the calibration trough from step 6 will need to be weighed on an accurate digital scale capable of producing pounds (in decimal form is preferred). If the scale displays pounds and ounces, divide the ounces by 16 and add the decimal to the pounds to get the complete weight.

8. Manipulate Seed Plates/Hydraulic Motor

If the weight of seed is within 10% of the target, the speed of the hydraulic motor can be modified to finetune the rate. Otherwise, the seed plates can be repositioned to dial the seed rate in closer to the target using the same method outlined in step 3. If the rate needs to increase, the setting will be increased; and likewise, the setting will decrease if the rate needs to be cut down.

9. Repeat Steps as Necessary

Until the target weight is achieved, steps 5 through 8 should be repeated. In some instances, the seed plates may need to be changed during this process. Don't fill hopper until calibration is complete.

ND-144 Calibration Chart																		
This Chart Lists the Weight of Seed Captured for One Minute (Target Weight) - STEP 4																		
Desired Seed Rate (Pounds/Acre) - STEP 2																		
		3	5	10	20	30	40	50	60	70	80	90	100	120	140	160	180	200
Ground Speed (MPH) - STEP 1	1	0.04	0.06	0.13	0.26	0.38	0.51	0.61	0.73	0.85	0.97	1.10	1.22	1.46	1.70	1.94	2.19	2.43
	1.5	0.05	0.09	0.18	0.35	0.53	0.70	0.91	1.10	1.27	1.46	1.65	1.82	2.18	2.54	2.90	3.29	3.65
	2	0.07	0.13	0.26	0.51	0.77	1.02	1.22	1.46	1.70	1.94	2.19	2.43	2.91	3.39	3.87	4.38	4.86
	2.5	0.09	0.15	0.30	0.61	0.91	1.22	1.52	1.82	2.12	2.42	2.74	3.04	3.64	4.24	4.84	5.48	6.08
	3	0.11	0.18	0.37	0.74	1.10	1.47	1.82	2.18	2.54	2.90	3.29	3.64	4.37	5.09	5.81	6.58	7.30
	3.5	0.13	0.21	0.42	0.83	1.25	1.66	2.13	2.55	2.97	3.39	3.84	4.26	5.10	5.94	6.78	7.67	8.51
	4	0.15	0.24	0.48	0.96	1.44	1.92	2.43	2.91	3.39	3.87	4.38	4.86	5.82	6.78	7.74	8.77	9.73
	4.5	0.16	0.27	0.54	1.09	1.63	2.18	2.74	3.28	3.82	4.36	4.94	5.47	6.55	7.63	8.71	9.86	10.94
	5	0.18	0.30	0.61	1.22	1.82	2.43	3.04	3.64	4.24	4.84	5.48	6.08	7.28	8.48	9.68	10.96	12.16
	5.5	0.20	0.33	0.66	1.31	2.05	2.62	3.34	4.01	4.66	5.32	6.03	6.69	8.01	9.33	10.65	12.06	13.38
	6	0.22	0.36	0.72	1.44	2.16	2.88	3.65	4.37	5.09	5.81	6.58	7.30	8.74	10.18	11.62	13.15	14.59
	6.5	0.24	0.39	0.78	1.57	2.35	3.14	3.95	4.74	5.51	6.30	7.13	7.90	9.46	11.02	12.58	14.25	15.81
	7	0.26	0.42	0.85	1.70	2.54	3.39	4.26	5.10	5.94	6.78	7.67	8.51	10.19	11.87	13.55	15.34	17.02
	7.5	0.27	0.45	0.90	1.79	2.69	3.58	4.56	5.46	6.36	7.26	8.22	9.12	10.92	12.72	14.52	16.44	18.24
	8	0.29	0.48	0.96	1.92	2.88	3.84	4.86	5.82	6.78	7.74	8.77	9.73	11.65	13.57	15.49	17.54	19.46
	8.5	0.31	0.52	1.04	2.08	3.12	4.16	5.17	6.19	7.21	8.23	9.32	10.34	12.38	14.42	16.46	18.63	20.67
9	0.33	0.55	1.10	2.21	3.31	4.42	5.47	6.55	7.63	8.71	9.86	10.94	13.10	15.26	17.42	19.73	21.89	
9.5	0.35	0.58	1.17	2.34	3.50	4.67	5.78	6.92	8.06	9.20	10.42	11.55	13.83	16.11	18.39	20.82	23.10	
10	0.37	0.61	1.22	2.43	3.65	4.86	6.08	7.28	8.48	9.68	10.96	12.16	14.56	16.96	19.36	21.92	24.32	

Figure 13. ND-144 Calibration Chart used for Step 4

Changing Seed Plates

The seed plates are strategically positioned between the hopper's outlet holes (seen when the hopper is empty) and the "cutoff plate" which the linear actuator shuttles back and forth to start and stop seed flow.

Each set of plates are labeled with laser etching on one side: "left", "right", and their respective sizes.

In order to change the seed plates, the hopper must be vacuumed/blown clean. If the plates are removed with seed in the hopper, the seed can wedge between the "cutoff plate" and the hopper outlets making it impossible to slide the next set of plates into place.

The seed plates are changed using the following steps:

1. To change plates you will need two 9/16" wrenches and the Adjuster Wrench, DS27-026. Using the small end of the Adjuster Wrench, located on top of chain cover as shown in Figure 9. Loosen and remove the two 1/2" carriage head bolts connecting the adjuster handle to the Adjuster mount as shown Figure 14.
2. Pull straight out on the adjuster handle and slide the seed plate assembly out of the seed box as shown in Figure 15.
3. Using the 9/16" wrenches, loosen and remove the 3/8" bolts connecting both seed plates to the adjuster linkages as shown in Figure 15.
4. Slide the plates and bushings out of linkages, set plates to the side, hold onto the bushings.
5. Select plates you want in machine and be sure to read etchings on plate ensuring both plates have the same size with corresponding sides.

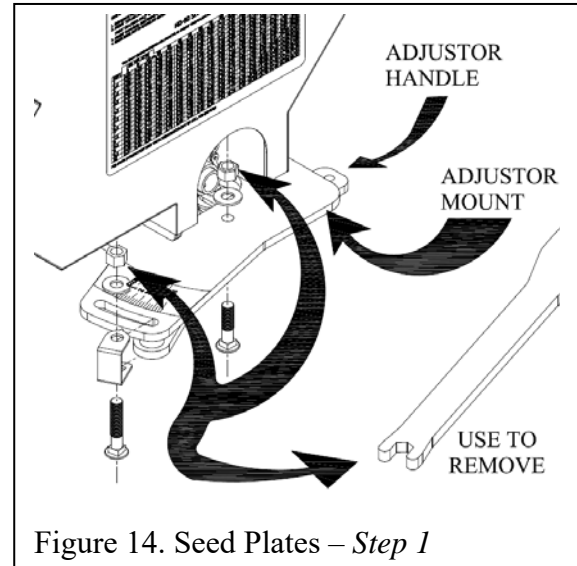

Figure 14. Seed Plates – Step 1

6. Reassemble the desired seed plate assembly; be sure the left and right plates are oriented as shown in Figure 15.
7. Take seed plate assembly and slide back into machine; be sure to put seed plates on top of cut off plate when starting to push them into the machine as shown in Figure 16.
8. Reattach the Adjuster Handle to the Adjuster Mount as shown in Figure 14, and fasten bolts.

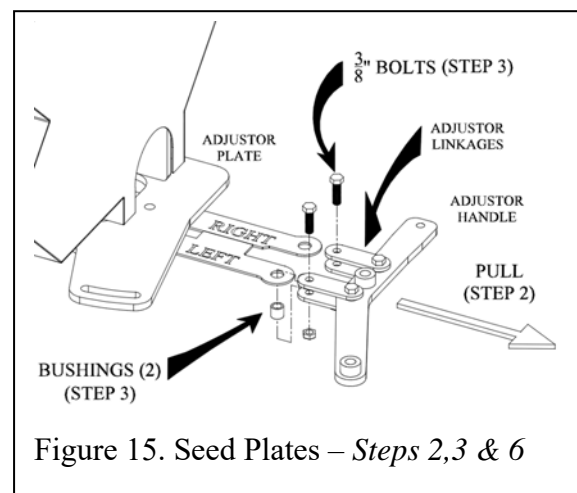

Figure 15. Seed Plates – Steps 2,3 & 6

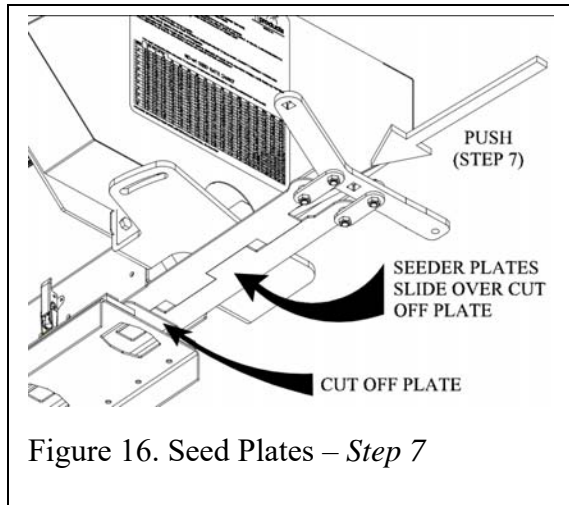

Figure 16. Seed Plates – Step 7

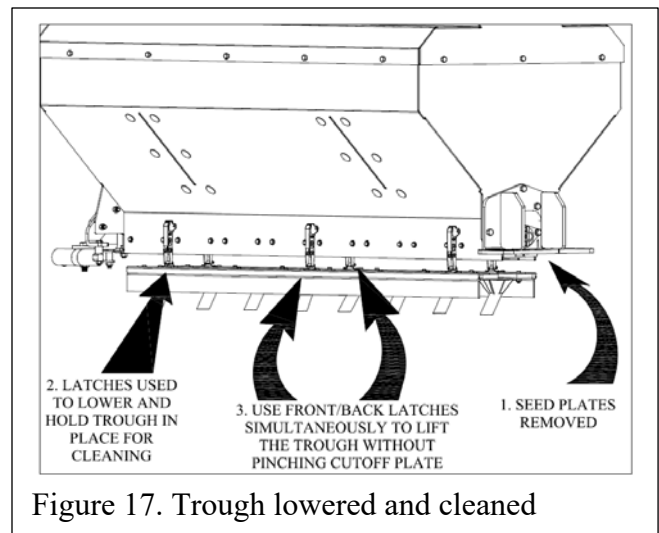

Figure 17. Trough lowered and cleaned

CLEANING

After Each Use

Remove large debris such as clumps of dirt, grass, crop residue, etc. from machine.

Inspect machine and replace worn or damaged parts.

Replace any safety decals that are damaged, missing, or not legible.

Grease bearings located on Coulter Disc shaft.

Oil and tighten (if necessary) all chains driving powered components.

Thoroughly clean hopper(s) vacuuming out all seed and debris from previous use.

Periodic or Before Extended Storage

Remove large debris such as clumps of dirt, grass, crop residue, etc. from machine.

Remove the remaining debris with a low-pressure washer spray:

1. Be careful when spraying near scratched or torn safety decals or near edges of decals as water spray can peel decal off surface.
2. Be careful when spraying near chipped or scratched paint as water spray may lift paint.
3. If a pressure washer is used, follow the advice of the pressure washer manufacturer.

Inspect machine and replace worn or damaged parts.

Check all hardware and ensure proper torque is present.

Sand down scratches and the edges of area of missing parts and coat with First Products spray paint of matching color.

Replace any safety decals with that are missing or not legible. See Safety Decals section for location drawing.

Cover the seeder with supplied tarp when the Multi-drill is being stored.

NOTE: Occasionally, it may be necessary to lower the trough as illustrated in Figure 18 to thoroughly clean all the moving components in the hopper to promote easier calibration and functionality in the future.

1. Remove Seed Plates as explained in previous section.
2. Use the latches to lower and hold the trough in place while using water or compressed air to clean all moving parts and their corresponding surfaces. If water is used, do not reassemble until everything is thoroughly dry.
3. It is best to use the latches on the front and back to simultaneously lift the trough back into place making sure not to pinch the Cut Off Plate between the trough and the hopper.
4. Install desired Seed Plates for future use.

WARRANTY INFORMATION

ONE YEAR LIMITED WARRANTY

FIRST PRODUCTS INC. WARRANTS THIS PRODUCT TO BE FREE OF DEFECTS IN MATERIALS AND WORKMANSHIP FOR A PERIOD OF TWELVE MONTHS FROM THE ORIGINAL DELIVERY DATE. THIS WARRANTY DOES NOT COVER PARTS CAUSED TO BE DEFICIENT DUE TO NORMAL WEAR, MISUSE, ACCIDENTS, OR LACK OF PROPER MAINTENANCE.

ANY PARTS THOUGHT TO BE DEFECTIVE MUST BE RETURNED FOR WARRANTY CONSIDERATION JOINTLY WITH FACTORY REPRESENTATIVES. A RETURN AUTHORIZATION NUMBER MUST BE OBTAINED AND CLEARLY MARKED ON ALL PACKAGES OF PARTS REQUIRING RETURN TO THE FACTORY.

THE OBLIGATION OF FIRST PRODUCTS INC. UNDER THIS WARRANTY SHALL BE EXCLUSIVELY LIMITED TO REPLACEMENT OF PARTS DETERMINED TO BE DEFECTIVE BY FIRST PRODUCTS INC. WITH FREIGHT PREPAID. IN NO EVENT SHALL FIRST PRODUCTS INC. BE LIABLE FOR INDIRECT, INCIDENTAL, OR CONSEQUENTIAL DAMAGES IN CONNECTION WITH THE USE OF THIS PRODUCT.

FIRST PRODUCTS INC. RESERVES THE RIGHT TO MAKE CHANGES OR ADD IMPROVEMENTS TO ITS PRODUCTS AT ANY TIME WITHOUT OBLIGATION TO MAKE SUCH CHANGES OR IMPROVEMENTS ON PRODUCTS SOLD PREVIOUSLY.

WARRANTY CLAIMS ARE PAID USING A JOB STANDARD (AUTHORIZING MAN HOURS) USING THE APPROPRIATE TIME FRAME ALLOWED FOR EACH PART REPLACED OR LABOR FUNCTIONS PERFORMED. THIS JOB STANDARD LIMITS THE MAN HOURS AUTHORIZED BY TASK. IT DOES NOT SET A SPECIFIC HOURLY RATE BUT LIMITS THE AUTHORIZED MAN HOURS THAT WILL BE PAID BY EACH TASK. MILEAGE IS NOT PAID.

FIRST PRODUCTS INC.

WARRANTY REGISTRATION CARD

WARRANTY VOID IF THIS CARD IS NOT ON FILE AT FIRST PRODUCTS INC.

DATE OF SALE _____

MODEL NUMBER _____ SERIAL NUMBER _____

CUSTOMER INFORMATION

NAME _____

ADDRESS _____

CITY _____ STATE _____ ZIP _____

ATTACHMENTS: TOW HTICH SMALL BOX

UNIT TO BE USED INWHAT APPLICATION (CHECK ALL THAT APPLY)

CITY/COUNTY EQUESTRIAN COM. LANDSCAPE

TURF/SOD FARM SPORTS FIELDS COVER CROP

FOOD PLOT PASTURE RENTAL

PLEASE HELP US DETERMINE THE BEST WAY TO ADVERTISE OUR PRODUCTS
& BRIEFLY EXPLAINED WHERE YOU HEARD ABOUT THIS EQUIPMENT:

REAL TREE KILLIN THE GAME SOCIAL MEDIA

ORGANIC SEARCH WORD OF MOUTH OTHER _____

RETURN THIS PORTION

(warranty card can be mailed removing this page, emailing it to sales@1stproducts.com or faxed to 229-382-0506)

CUSTOMER'S RECORD

MODEL NUMBER _____

SERIAL NUMBER _____

DATE PURCHASED _____

FIRST PRODUCTS INC.
1-800-363-8780
E-mail: sales@1stproducts.com

**AFTER COMPLETING,
REMOVE MANUFACTURERS
CARD, FOLD, STAPLE
CORNERS, STAMP & MAIL.**

CUT ALONG LINE TO REMOVE

PLACE
STAMP
HERE

**FIRST PRODUCTS INC.
164 OAKRIDGE CHURCH RD.
TIFTON, GA 31794**

ROW UNIT GROUP

ITEM	PART NO	DESCRIPTION	QTY	ITEM	PART NO	DESCRIPTION	QTY	ITEM	PART NO	DESCRIPTION	QTY
1	FL50-008	CAT. 0 TOP LINK	1	14	HW32020TAZP	5/8 Lockwasher	2	27	ND27-071	SCRAPER GAUGE, RT (ND81-028)	1
2	HW01008024G2ZPC	1/4 X 3/4 HHCS	1	15	HW42010064ZP	5/16 X 2 ROLL PIN	5	28	ND27-076	No-Till Rock Gaurd 13.5"	1
3	HW01010024G5PLC	5/16 X 3/4 HHCS	4	16	HW6002003218GZP	5/8 ID X 1 OD 18 GA. M.B.	6	29	ND50-001	DUAL RIB PRESS WHEEL	1
4	HW01020056G5ZPC	5/8 x 1 3/4 HHCS G5	1	17	HW6004006010GZP	1 1/4 x 1-7/8 x 10 GA. M.B.	5	30	ND50-006	13.5" SEED DISK	2
5	HW01020056G5ZPD	5/8 x 1 3/4 HHCS G5 Left hand	1	18	ND24-005	GAUGE ARM SPACER 1	1	31	ND80-005	OFFSET DISK OPENER LEG; LT (ND81-027)	1
6	HW01020096G5ZPC	5/8 X 3 HHCS	1	19	ND24-006	GAUGE ARM SPACER 2	1	32	ND80-006	OFFSET DISK OPENER LEG; RT (ND81-028)	1
7	HW01020160G5ZPC	5/8 X 5 HHCS	2	20	ND24-007	PRESS WHEEL SPACER	2	33	ND80-046	SEED TUBE; Left (ND81-027)	1
8	HW08010016PLC	5/16 X 1/2 SET SCW	2	21	ND26-020	MASTER PIN: R.U.	1	34	ND80-047	SEED TUBE; Right (ND81-028)	1
9	HW20020G5ZPC	5/8 HEX NUT	2	22	ND26-021	FULCRUM PIN: R.U.	1	35	ND81-001	SEE DIAMOND MOUNT GROUP	1
10	HW22008G5ZPC	1/4 FLG. LOCK NUT	1	23	ND27-015	SCRAPER	1	36	ND81-002	SEE DIAMOND MOUNT GROUP	1
11	HW22010G5PLC	5/16 FLG. LOCK NUT	4	24	ND27-068	SCRAPER ARM; LT (ND81-027)	1	37	ND81-003	SEE PRESS WHEEL ARM GROUP	1
12	HW24020GBZPC	5/8 STOVER LOCK NUT	1	25	ND27-069	SCRAPER ARM; RT (ND81-028)	1	38	ND81-004	SEE PRESS WHEEL ARM GROUP	1
13	HW30020G8ZPC	5/8" Flatwasher G8	1	26	ND27-070	SCRAPER GAUGE, LT (ND81-027)	1	39	ND81-009	SEE SPRING ROD GROUP	1

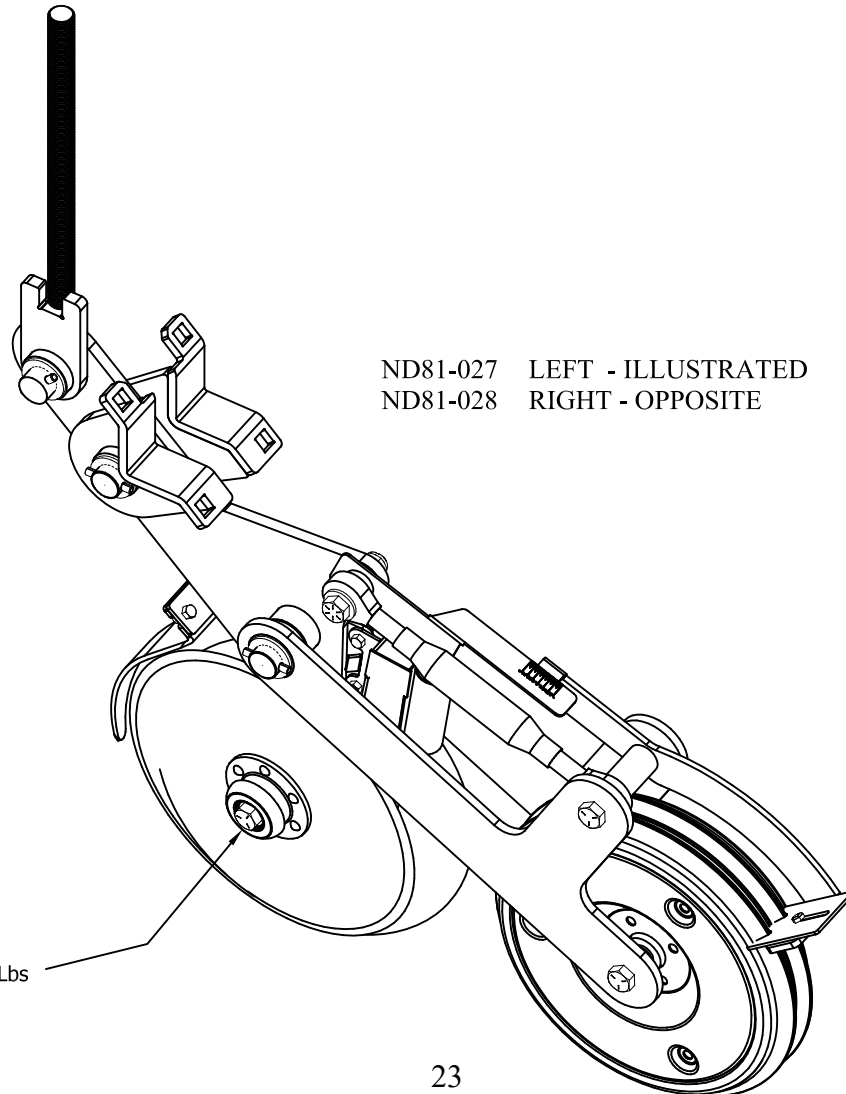

TORQUE SEED DISCS TO 128 Ft-Lbs

ROW UNIT GROUP

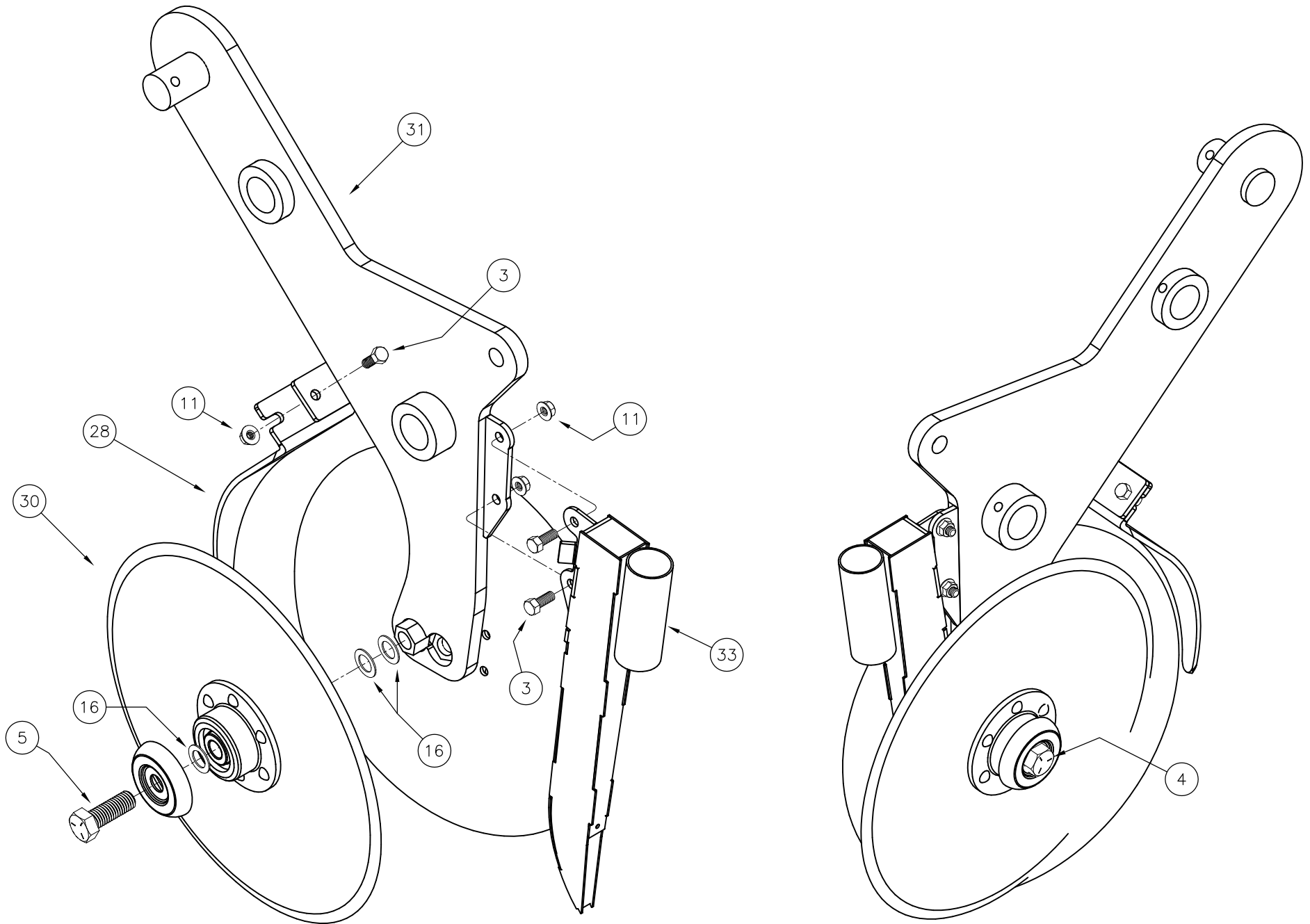

ROW UNIT GROUP

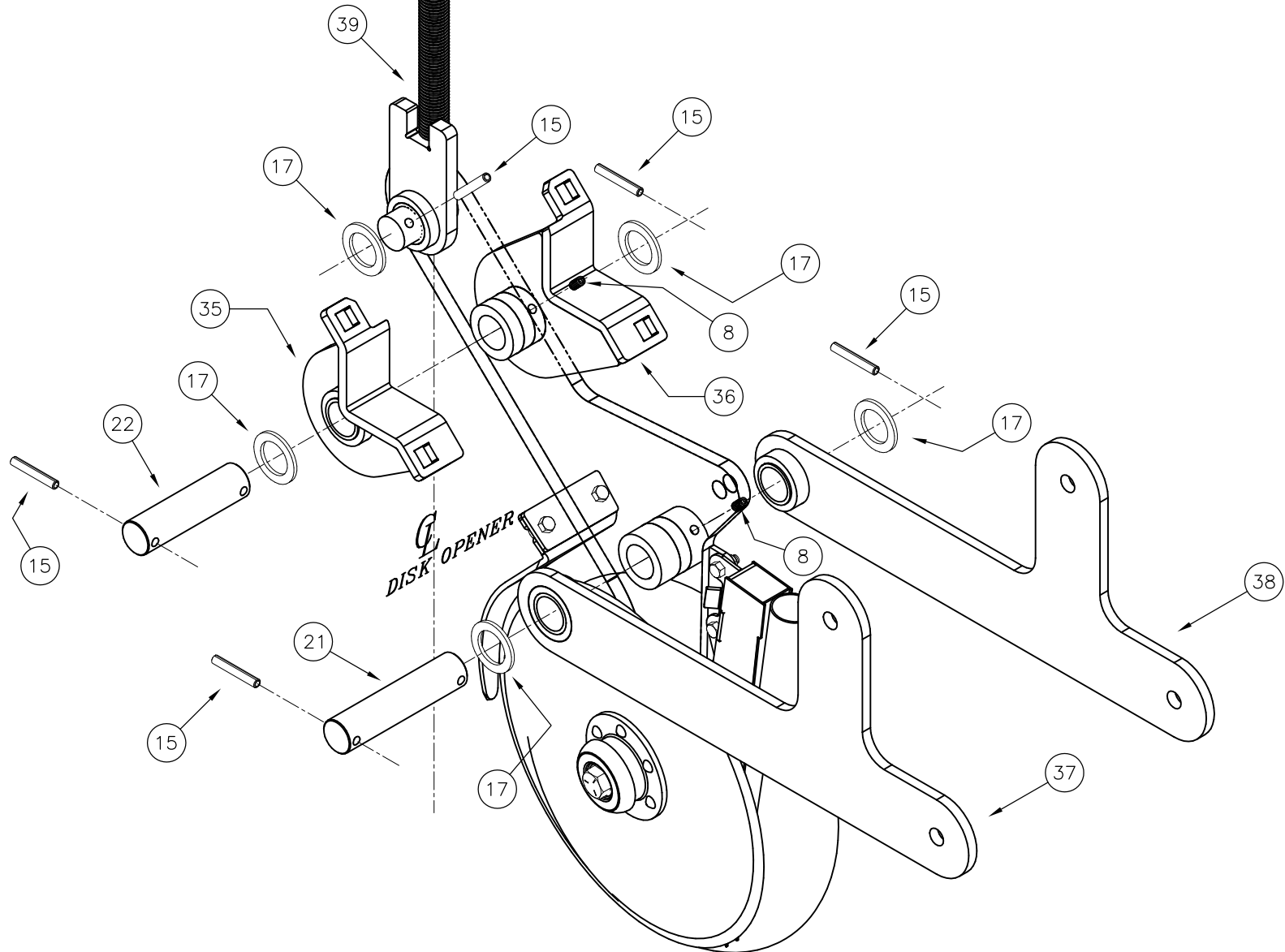

ROW UNIT GROUP

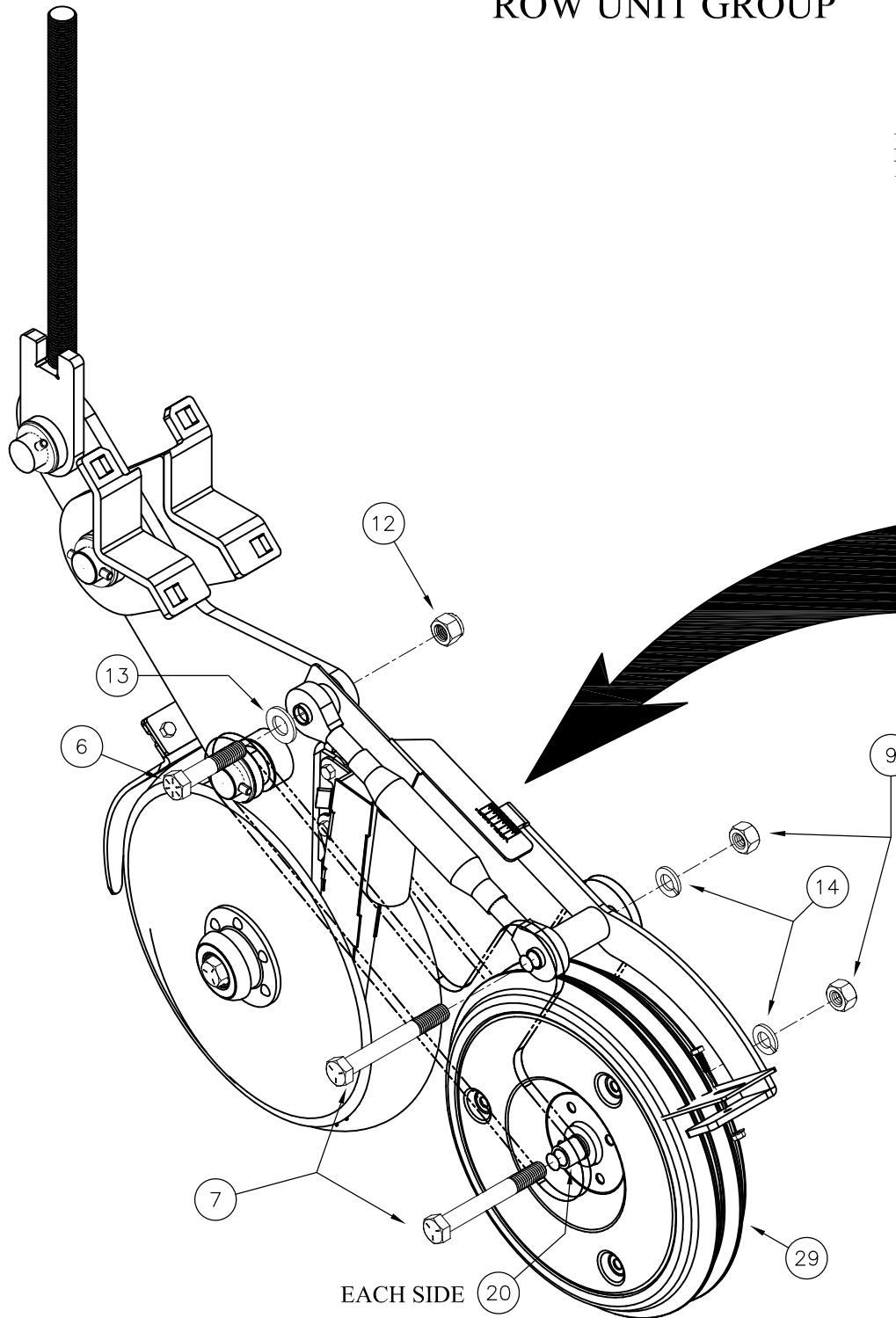

EXPLODED VIEW BETWEEN PRESS WHEEL ARMS:
NOTE SHOULDER OF SPACER ORIENTED INTO GAUGE ARM

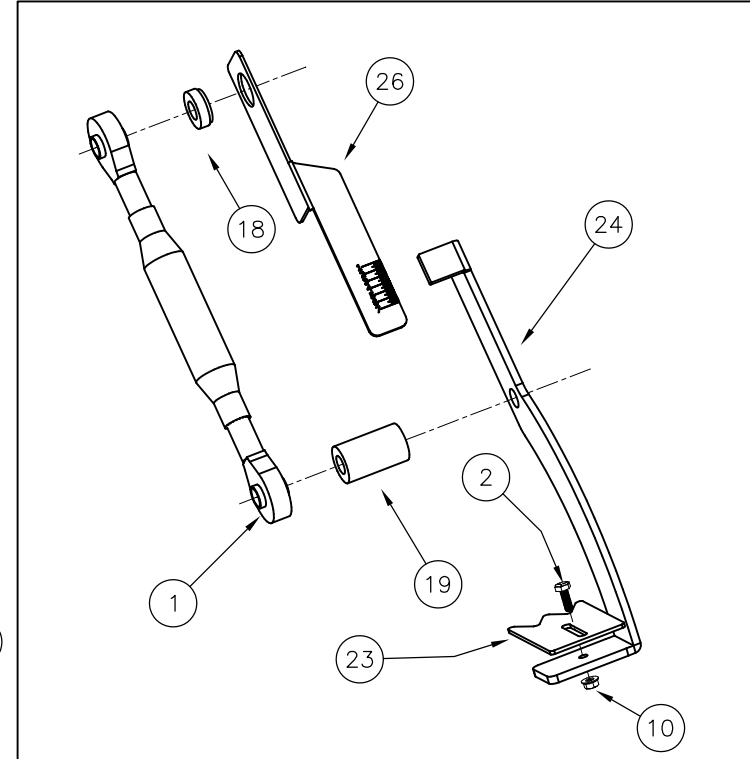

SPRING ROD GROUP

ITEM	PART NO	DESCRIPTION	QTY
1	ND80-004	SPRING ROD	1
2	ND50-009	1-1/4" ID PLASTIC BUSHING	1

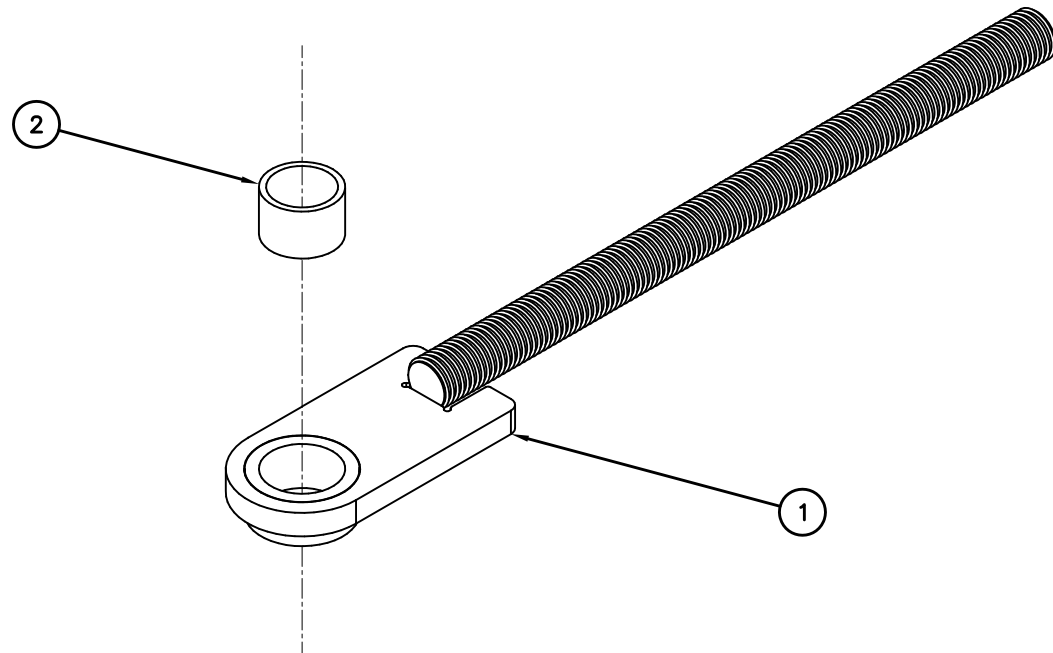

PRESS WHEEL ARM GROUP

ITEM	PART NO	DESCRIPTION	QTY
1	ND80-009	PRESS WHEEL ARM; LT (003)	1
2	ND80-010	PRESS WHEEL ARM; RT (004)	1
3	ND50-009	1-1/4" ID PLASTIC BUSHING	1

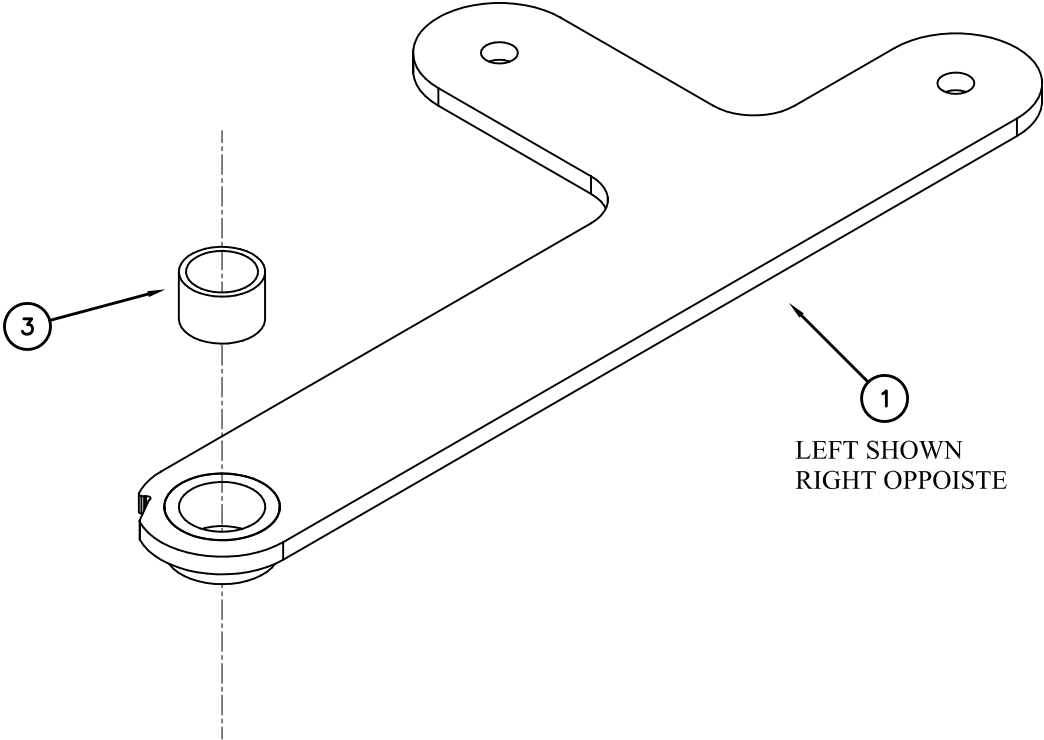

FRAME GROUP

ITEM	PART NO	DESCRIPTION	QTY	ITEM	PART NO	DESCRIPTION	QTY	ITEM	PART NO	DESCRIPTION	QTY
1	AE50-059	SMALL FP DECAL	2	24	HW24012G5ZPC	3/8 STOVER LOCK NUT	4	47	UA50-007	3/16 LYNCH PIN	2
2	AE50-156	BRIDGE PIN	2	25	HW24016GBZPC	1/2 Stover Lock Nut	4	48	ND50-013	6000 LB AXLE SPD & HUB KIT	2
3	AG26-003	STAND PIN	2	26	HW24020GBZPC	5/8 STOVER LOCK NUT	28	49	ND50-022	27-37" CAT. 2 TOPLINK	2
4	DS50-067	DECAL - GENERAL WARNING	1	27	HW24024GBZPC	3/4 STOVER LOCK NUT	16	50	ND50-023	Cat. 2 TOPLINK PIN	1
5	DS50-068	DECAL - OPERATOR WARNING	1	28	HW24032GBZPC	1 STOVER LOCK NUT	4	51	ND50-065	IGUS 2"ID Bushing	4
6	FA50-060	STEP LIFT PIN	2	29	HW25032G5ZPC	1" JAM NUT	16	52	ND80-013	TOP DIAMOND BAR MOUNTS 3 X 3	16
7	FA50-061	SPACER, CAT 3	2	30	HW26020G5ZPF	5/8 LUG NUT	16	53	ND80-015	12FT MAIN FRAME WELDMENT	1
8	HW01010096G5ZPC	5/16 X 3 HHCS	4	31	HW30010TAZP	5/16 FLATWASHER	6	54	ND80-021	GAUGE WHEEL LIFT TUBE	2
9	HW01012032G5ZPC	3/8 X 1 HHCS	4	32	HW31020TAZP	5/8 SAE WASHER	20	55	ND80-022	GAUGE WHEEL MOUNT; LH	1
10	HW01016112G5ZPC	1/2 X 3 1/2 HHCS	4	33	HW31024TAZP	3/4 SAE WASHER	18	56	ND80-023	GAUGE WHEEL MOUNT; RH	1
11	HW010200048G5ZPC	5/8 X 1 1/2 HHCS	4	34	HW36032G8ZPC	1" HEAVY HEX NUT ZINC PL.	16	57	ND81-026	12" Walk Board ASSM.	1
12	HW01020064G5ZPC	5/8 X 2 HHCS	8	35	ND24-013	WALK BOARD MOUNT	2	58	ND81-027	ND ROW UNIT; LEFT	8
13	HW01020144G5ZPC	5/8 X 4 1/2 HHCS	4	36	ND26-019	ND-144 GAUGE WHEEL PINS	2	59	ND81-028	ND ROW UNIT; RIGHT	8
14	HW01020208G5ZPC	5/8 X 6 1/2 HHCS	12	37	ND27-016	SPRING WASHER	16	60	ND81-042	ND72 SHAFT ASSY - 16" DISC X 9"	2
15	HW01024064G5ZPC	3/4 x 2 G5 HHCS	14	38	ND27-039	WALK BOARD HANGER	2	61	ND50-014	LARGE FRAME GAUGE WHEEL	2
16	HW01024160G5ZPC	3/4 x 5 G5 HHCS	4	39	ND27-099	C-SHANK MOUNT PLATES	8	62	SE50-035	HITCH PIN	3
17	HW01032128G8ZPC	1 x 4 G8 HHCS	4	40	ND27-101	COVER BOX TOP	2	63	UA50-009	OM CANISTER	1
18	HW03020072G5ZPC	5/8 X 2 1/4 CARR. BOLT	64	41	ND27-102	COVER BOX CATCH	2	64	ND50-053	ND-144 DECAL	1
19	HW06008016G5ZPC	1/4 X 1/2 FLANGE LOCK SCREW	10	42	ND27-133	ND STEP SIDE; LEFT	1	65	ND50-054	MULTI-DRILL DECAL	1
20	HW06010024G5ZPC	5/16 X 3/4 FLANGE LOCK SCREW	2	43	ND27-134	ND STEP SIDE; RIGHT	1	66	AG50-089	RIDER HAZARD DECAL	1
21	HW22008G5ZPC	1/4 FLANGE LOCK NUT	10	44	ND27-135	STEP - ND	1	67	ND27-144	C-SHANK MOUNT 3/4	4
22	HW22020G5ZPC	5/8" FLG. LOCK NUT	64	45	ND50-002	C-FLEX SHANK	4				
23	HW24010GBZPC	5/16 STOVER LOCK NUT	6	46	ND50-008	2.5" X 9.5" COMP. SPRING	16				

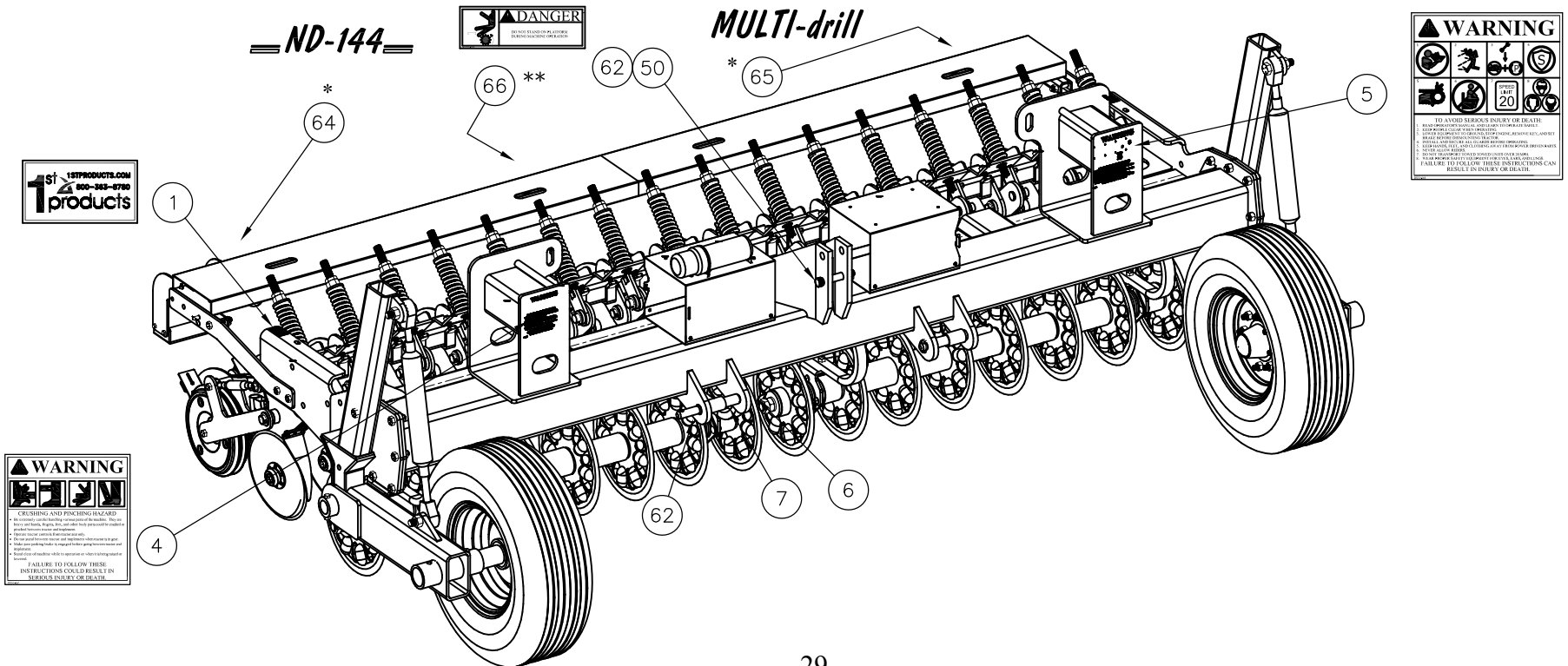

FRAME GROUP

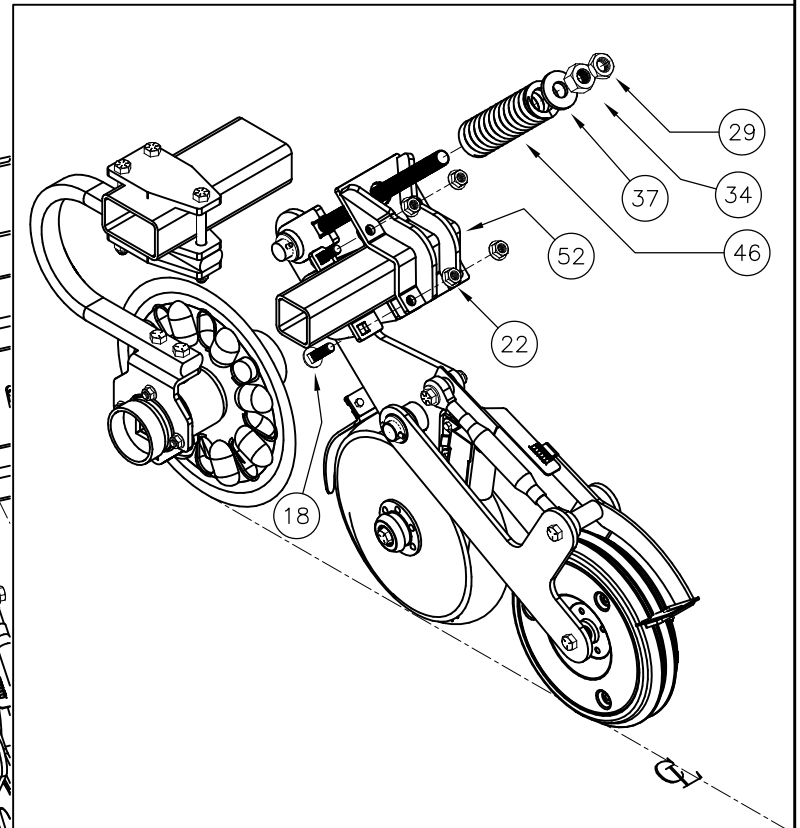
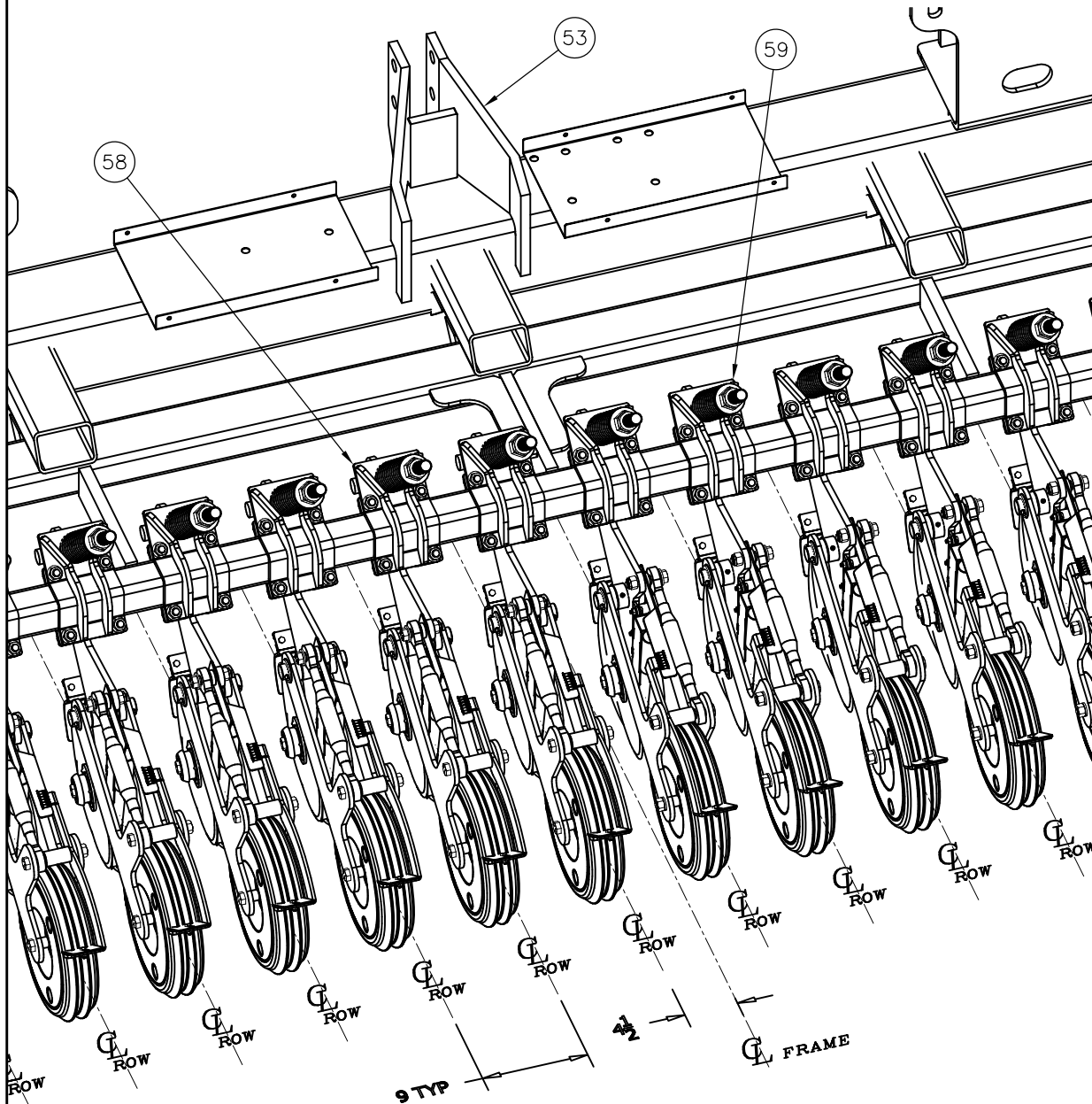

CUT AWAY VIEW SHOWING COMPONENTS TO ASSEMBLE EACH ROW UNIT ON TOOLBAR AS SHOWN LEFT (LEFT HAND ASSEMBLY SHOWN ABOVE)

FRAME GROUP

NOTE:
BEWARE OF ORDER OF
PLACEMENT OF ND27-099 &
ND27-144 AS SHOWN LEFT

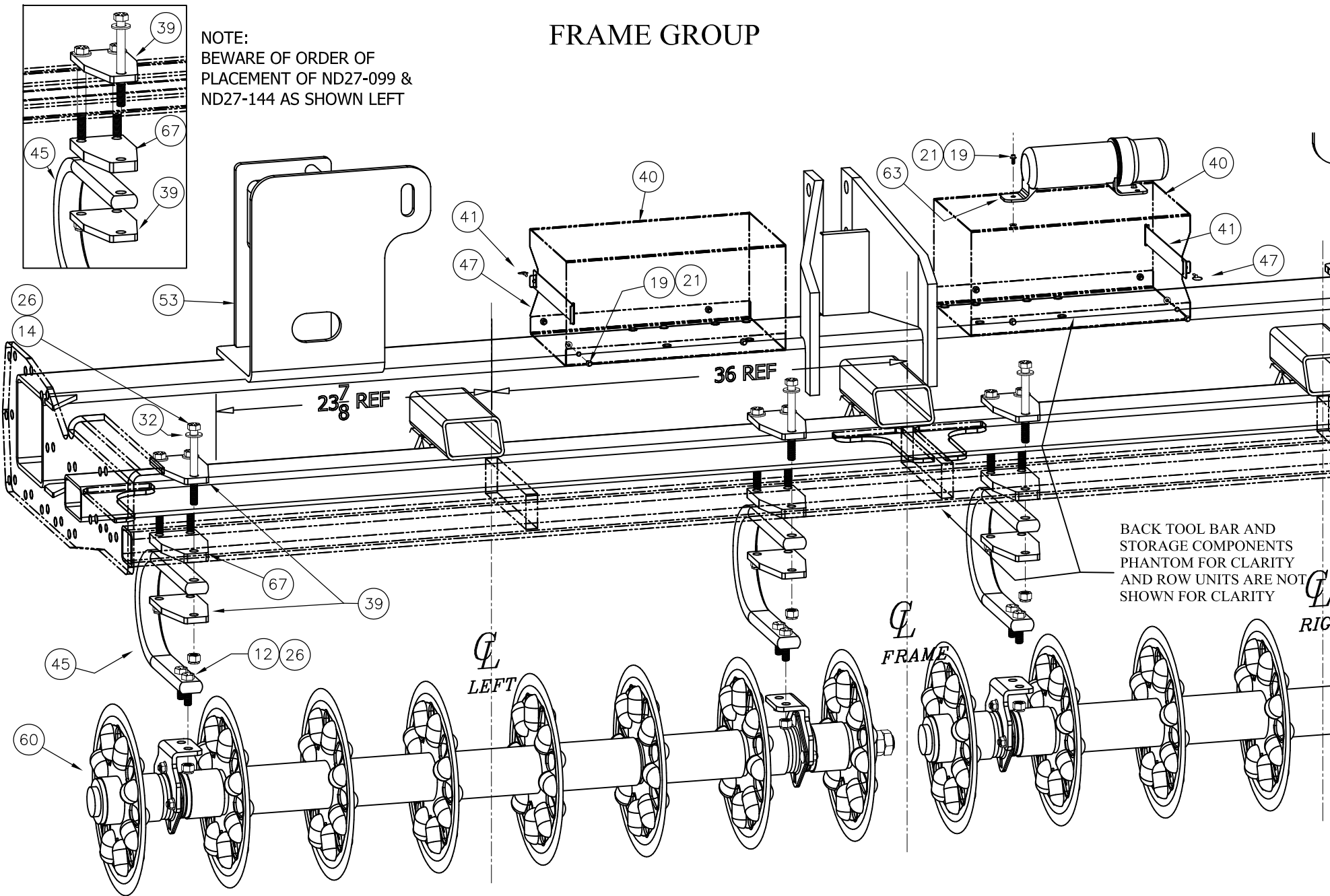

BACK TOOL BAR AND
STORAGE COMPONENTS
PHANTOM FOR CLARITY
AND ROW UNITS ARE NOT
SHOWN FOR CLARITY

LEFT

FRAME

RIGHT

FRAME GROUP

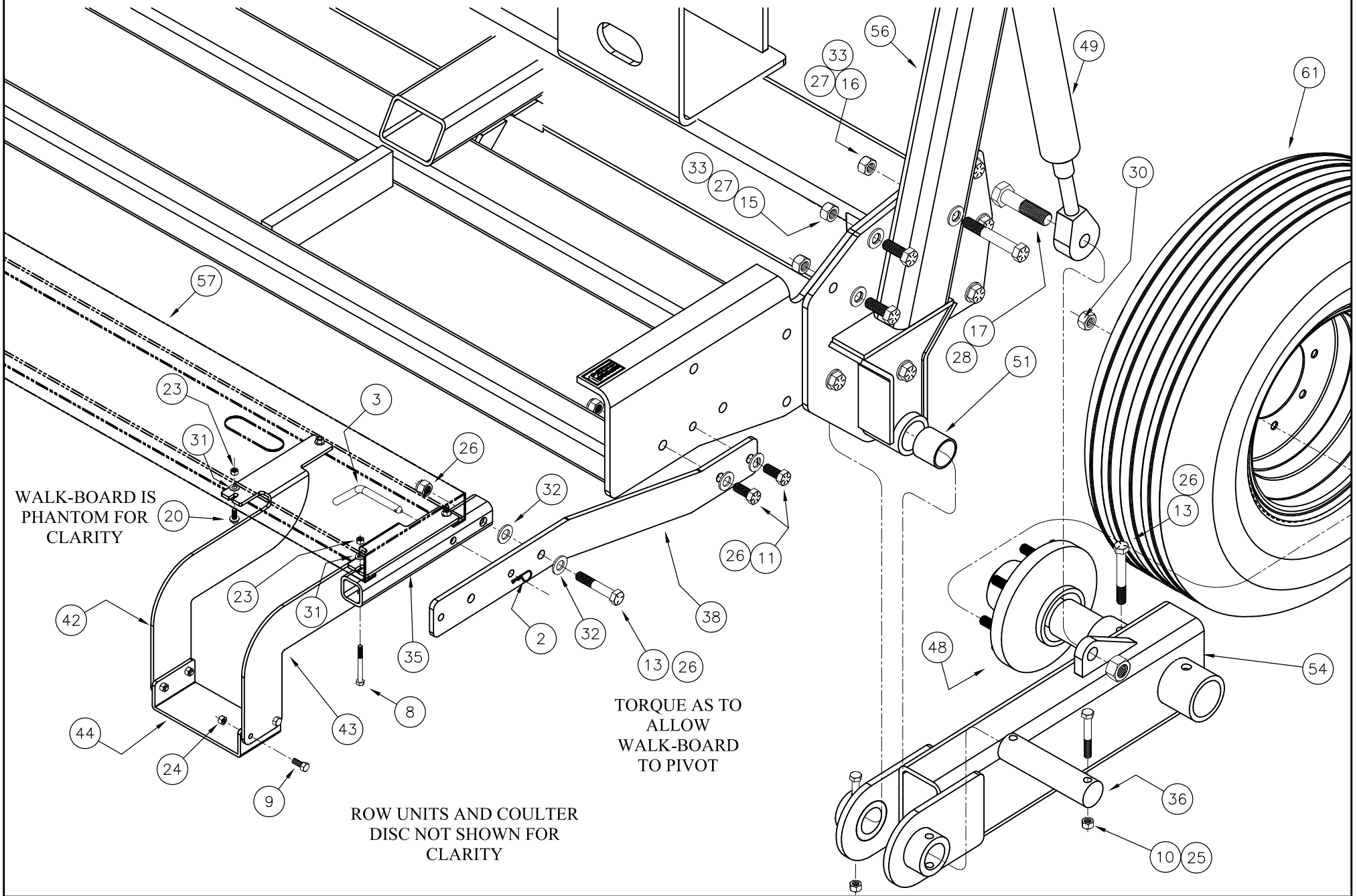

COULTER SHAFT GROUP

ITEM	PART NO	DESCRIPTION	QTY	ITEM	PART NO	DESCRIPTION	QTY	ITEM	PART NO	DESCRIPTION	QTY
1	HW03016040G5ZPC	1/2" X 1-1/4" CARR. BOLT	6	5	ND27-041	BEARING HANGER	2	9	ND80-029	9" SPACER	5
2	HW22016G5ZPC	1/2" FL. NUT	6	6	ND50-003	1-1/4" BORE BEARING	2	10	ND80-030	9" BEARING SPACER	4
3	HW25040G5ZPC	1-1/4" JAM NUT ZPL	2	7	ND50-007	16" BUBBLE COULTER	8	11	ND80-045	AXLE END CAP ND-72	2
4	HW33040G8ZP	1-1/4" LOCK WASHER HVY	1	8	ND50-010	8 OUTLET 9" SPAC. DISK AXLE	1				

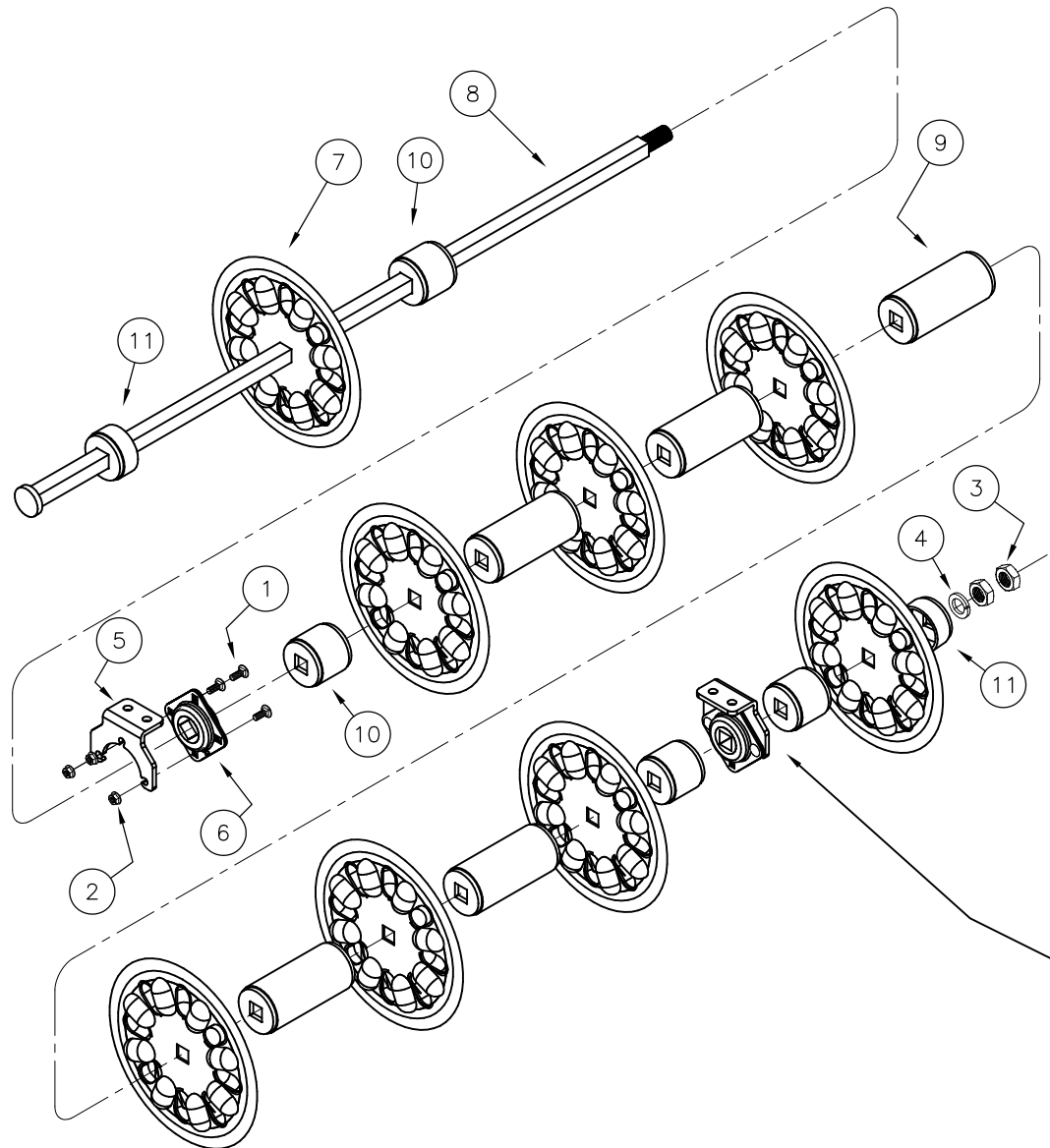

TORQUE 1 1/4" JAM NUT TO 475-500 FT-LBS (RECOMMENDED)

ORIENT GREASE FITTINGS IN SAME DIRECTION OF TRAVEL AND POINTING OUTWARDLY FOR EASIER MAINTENANCE BY USER

FRAME TO SEEDER GROUP

ITEM	PART NO	DESCRIPTION	QTY	ITEM	PART NO	DESCRIPTION	QTY	ITEM	PART NO	DESCRIPTION	QTY
1	DS26-007	BOX CONNECTOR 12FT	1	15	DS50-046	POWER HARNESS W/ TEST CLIPS	1	29	DS81-013	DS SWITCH HARNESS ASSM.	1
2	DS27-032	LEFT SEED PLATE 1"	2	16	DS50-104	ADAPTER, #8 MJIC x #8 MJIC, 90 DEG	2	30	DS81-029	PRIMARY HOPPER - DS72 RT	1
3	DS27-033	RIGHT SEED PLATE 1"	2	17	DS50-106	HYD HOSE A	2	31	DS81-075	PRIMARY HOPPER - DS72 HYD.	1
4	DS27-036	LEFT SEED PLATE 1/2"	2	18	DS50-107	HYD HOSE B	2	32	ND81-017	ND144 FRAME ASSEMBLY	1
5	DS27-037	RIGHT SEED PLATE 1/2"	2	19	DS50-108	HYD HOSE C	1	33	HW01010048G5ZPC	5/16 x 1-1/2 HHCS	2
6	DS27-038	LEFT SEED PLATE 3/8"	2	20	DS50-109	HYD HOSE D	1	34	HW01020160G5ZPC	5/8 X 5 HHCS	16
7	DS27-039	RIGHT SEED PLATE 3/8"	2	21	DS50-122	SINGLE DIRECTION FLOW MALE TIP	1	35	HW06008024G5ZPC	1/4 X 3/4 FLANGE LOCK SCREW	2
8	DS27-040	LEFT SEED PLATE 1/4"	2	22	FA50-068	QUICK COUPLER MALE	1	36	HW24008G5ZPC	1/4 STOVER LOCK NUT	2
9	DS27-041	RIGHT SEED PLATE 1/4"	2	23	ND50-016	6 FT TARP	2	37	HW24010G5ZPC	5/16 STOVER LOCKNUT	2
10	DS27-055	SEEDBOX BOTTOM MNT.	4	24	ND50-024	1" ID X 1 1/4" OD CVT	16	38	HW24020G5ZPC	5/8 STOVER LOCK NUT	16
11	ND27-193	7/8 HOSE CLAMP BOTTOM	1	25	ND50-083	ND-144 SERIAL # TAG	1	39	HW41020TAZP	5/8 SAE FLATWASHER	16
12	ND27-194	7/8 HOSE CLAMP TOP	1	26	ND50-094	ND144 PARTSBOOK	1	40	HW30010G5ZPC	5/16 FLATWASHER	2
13	ND27-200	DOUBLE BEND HOSE CLAMP	1	27	SB50-062	1 3/8 HOSE CLAMP	16				
14	AG50-084	SMV SIGN	1	28	ND80-032	ND-72 CALIBRATION TROUGH	2				

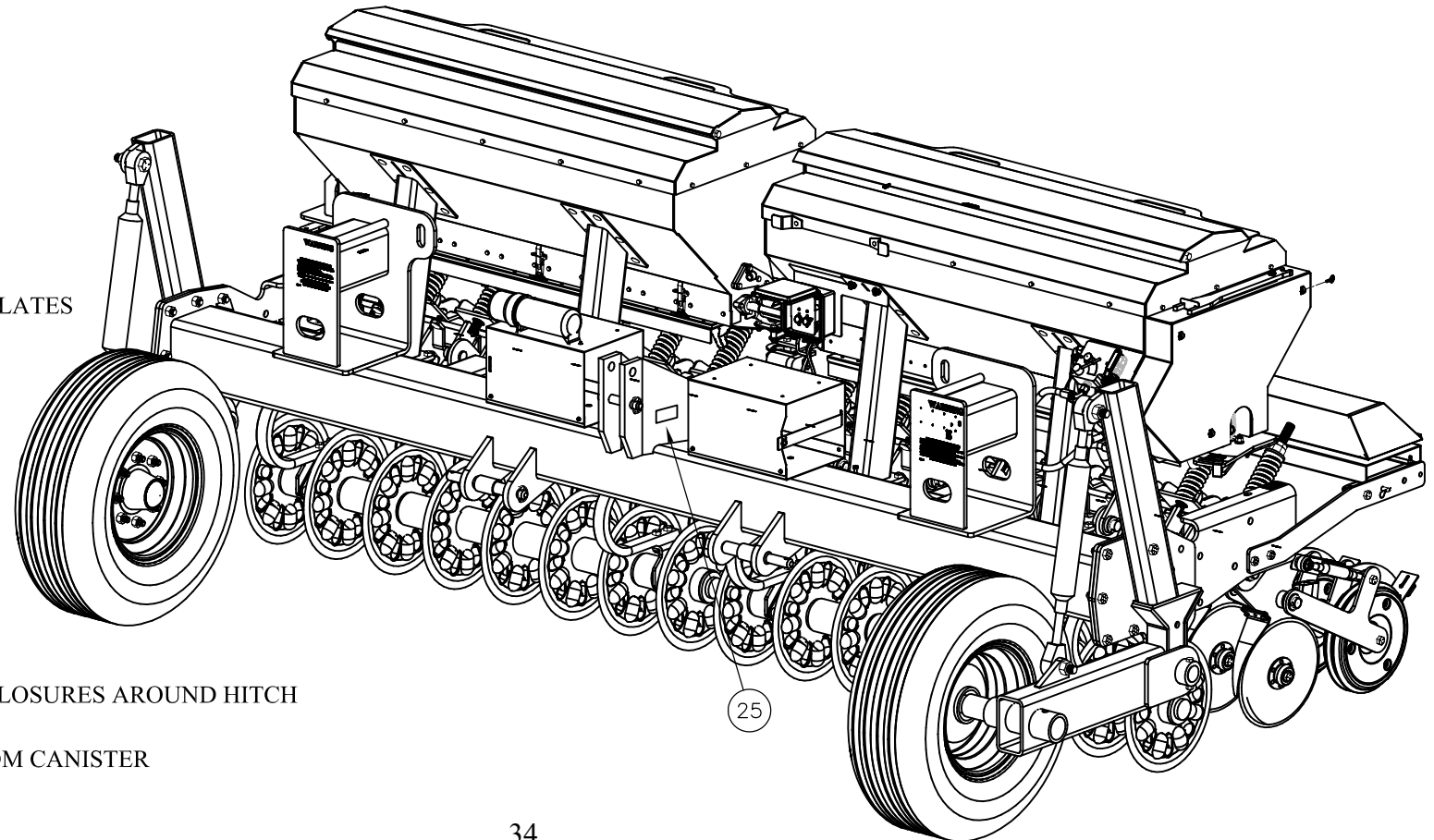

2
3
4
5
6
7
8
9

ADDITIONAL SEED PLATES

23 TARP IS STORED INSIDE ENCLOSURES AROUND HITCH

26 PARTS BOOK IS STORED IN OM CANISTER

28 CALIBRATION TROUGH

FRAME TO SEEDER GROUP

MANY COMPONENTS
LEFT OUT OF VIEW FOR
CLARITY

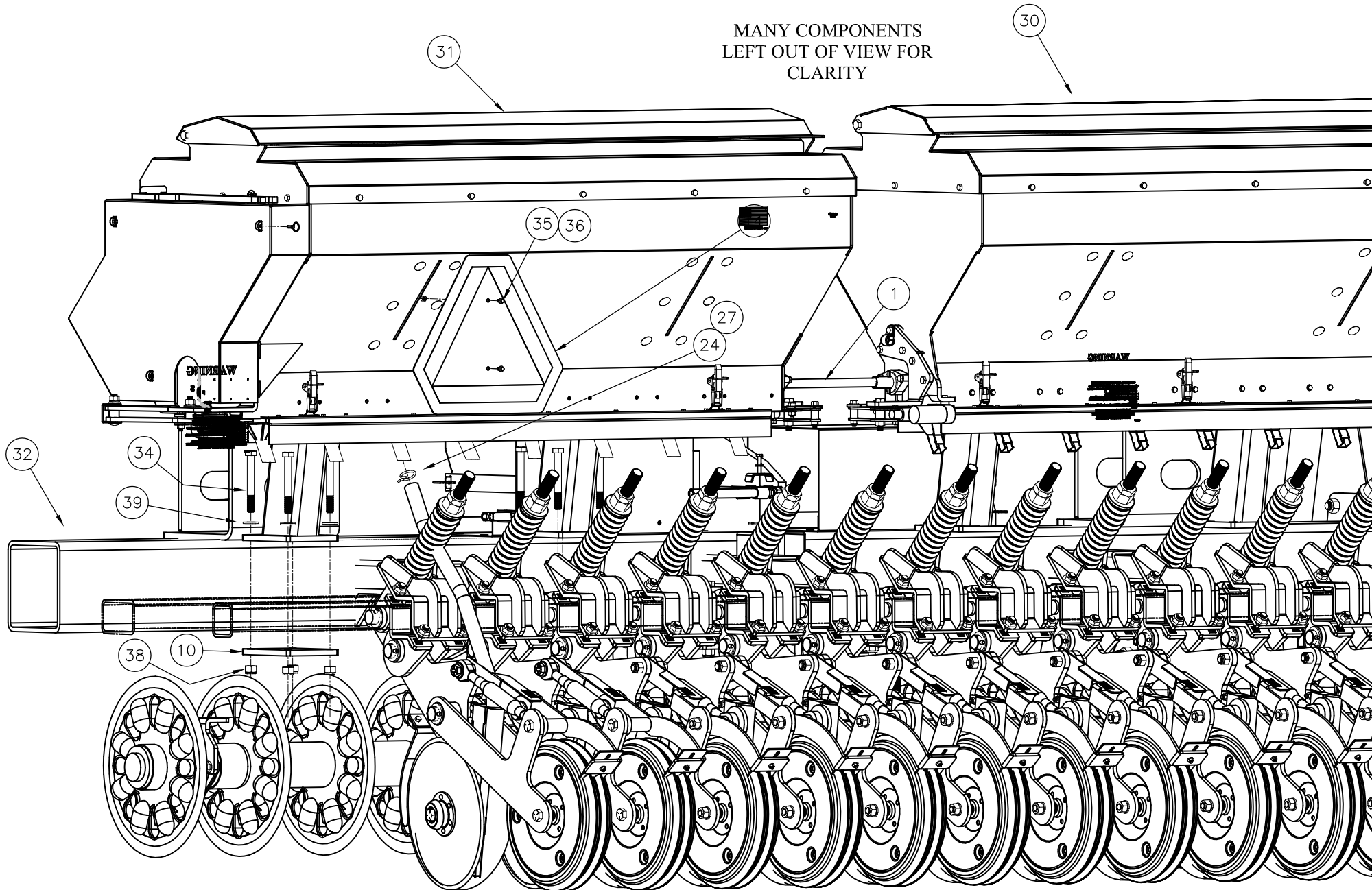

FRAME TO SEEDER GROUP

PART PHANTOMED FOR CLARITY

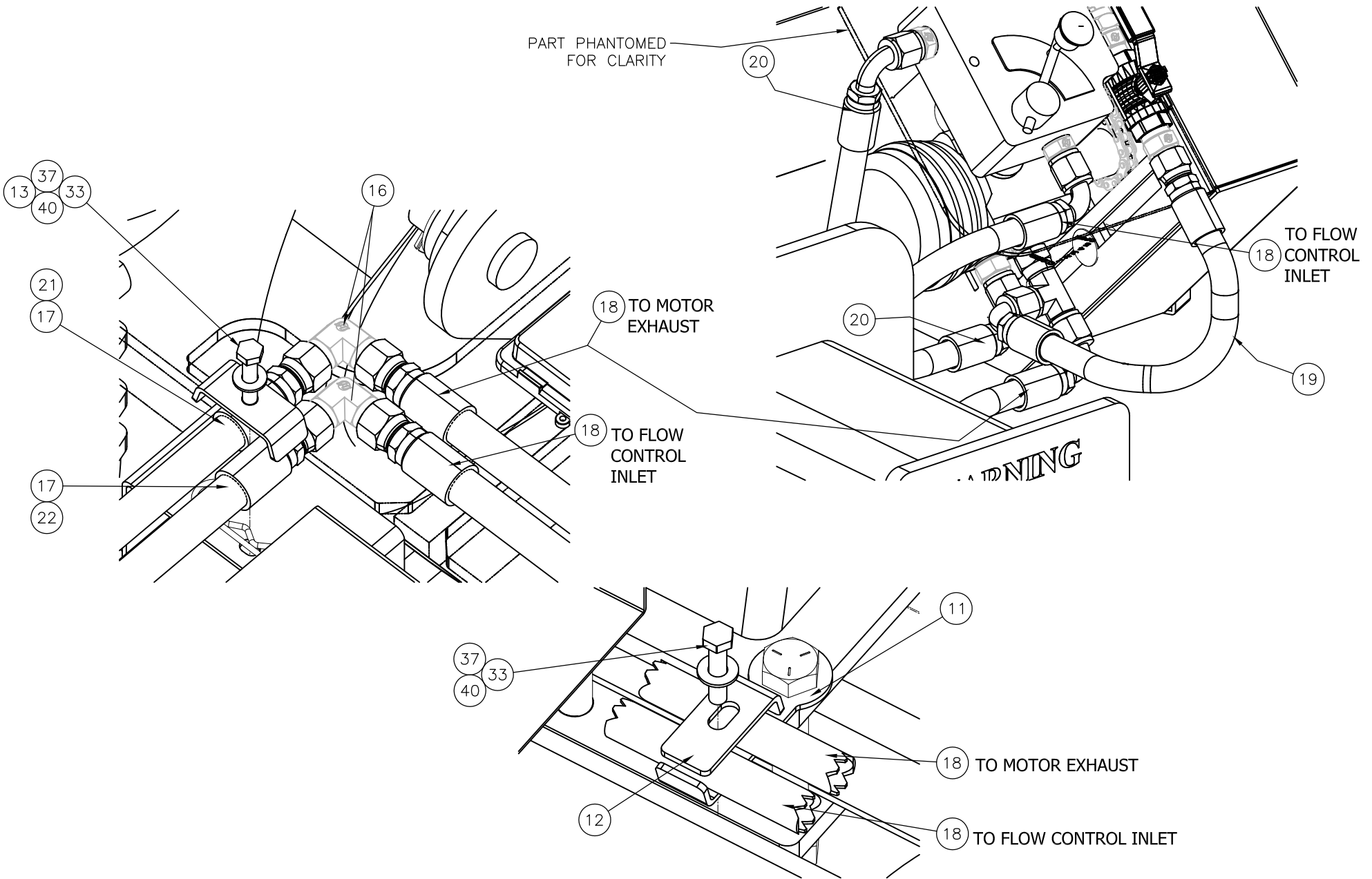

PRIMARY HOPPER GROUP

ITEM	PART NO	DESCRIPTION	QTY	ITEM	PART NO	DESCRIPTION	QTY	ITEM	PART NO	DESCRIPTION	QTY
1	AE50-075	PINCH POINT CAUTION DECAL	1	29	DS50-082	DS PATENT DECAL	1	57	HW01012144G5ZPC	3/8 X 4 1/2 HHCS	2
2	DS24-004	METER PLATE BUSHINGS	4	30	DS50-096	BUFFER O-RING	3	58	HW01016040G5ZPC	1/2 X 1-1/4 HHCS	1
3	DS24-011	CUT OFF PLATE BUSHINGS	2	31	DS50-105	#35 x 76 PITCH CHAIN	1	59	HW01016080G5ZPC	1/2 X 2 1/2 HHCS ALL THREAD	2
4	DS24-016	IDLER SPACERS	2	32	DS80-003	DS-72 LID	1	60	HW03016032G5ZPC	1/2 X 1 Carriage Bolt	26
5	DS24-028	LID BUSHING	2	33	DS80-006	Meter Adj. Bracket	1	61	HW03016040G5ZPC	1/2 X 1 1/4 CARRIAGE BOLT	3
6	DS26-001	AGITATOR SHAFT BEARING	2	34	DS80-009	SEEDBOX MOUNT	2	62	HW03016072G5ZPC	1/2 x 2 1/4 CARRIAGE BOLT	1
7	DS26-003	ACTUATOR SPACER 1	1	35	DS80-035	METER ADJUSTER	1	63	HW03016080G5ZPC	1/2 X 2 1/2 CARRIAGE BOLT	1
8	DS26-004	ACTUATOR SPACER 2	1	36	DS80-051	DS-72 CAP	1	64	HW06008016G5ZPC	1/4 X 1/2 FLANGE LOCK SCREW	32
9	DS26-005	ACTUATOR SPACER 3	1	37	DS80-053	DS-72 SPLASH GUARD	1	65	HW20012G5ZPC	3/8 HEX NUT	2
10	DS27-012	SEED FUNNEL 1	6	38	DS80-080	DS-72 PRIMARY HOPPER HYD.	1	66	HW20016G5ZPC	1/2 HEX NUT	4
11	DS27-013	SEED FUNNEL 2	2	39	DS80-082	AGITATOR DRIVE SPKLT. #35 CHAIN	1	67	HW24008GBZPC	1/4 Stover Lock Nut	32
12	DS27-020	Actuator Mount	1	40	DS81-005	ACTUATOR ASSEMBLY	1	68	HW24010GBZPC	5/16 Stover Lock Nut	21
13	DS27-021	Actuator Linkage Pivot	1	41	DS81-052	SPOUT TRAY - DS72	1	69	HW24012GBZPC	3/8 Stover Lock Nut	18
14	DS27-022	METER PLATE LINKAGES	4	42	DS81-053	AGITATOR - DS72	1	70	HW31010TAZP	5/16 SAE Flat Washer	8
15	DS27-024	CUT OFF PLATE LEVER ACTION	2	43	DS81-074	DS HYD. REDUCTION ASSM.	1	71	HW31012TAZP	3/8 SAE FLATWASHER	4
16	DS27-027	METER SCALE POINTER	1	44	DS81-079	DS HYD. CHAIN GAURD	1	72	HW31016TAZP	1/2 SAE FLATWASHER	5
17	DS27-034	LEFT SEED PLATE 3/4"	1	45	DS81-080	DS HYD. MOTOR ASSM.	1	73	HW32012G5ZP	3/8 LOCKWASHER	2
18	DS27-035	RIGHT SEED PLATE 3/4"	1	46	DS81-081	DS HYD. FLOW CONTROL ASSM.	1	74	HW32016G5ZP	1/2 LOCK WASHER	3
19	DS27-044	CUT OFF PLATE	1	47	DS81-082	DS HYD. PRIMARY IDLER ASSEMBLY	1	75	HW34016G5ZPC	1/2 2-WAY LOCKUT	3
20	DS27-083	CUT OFF PLATE BUSHING LINKAGE	1	48	DS81-084	ACTUATOR SWITCH BOX	1	76	HW35016G5ZPC	1/2 FLANGE STOVER LOCKNUT	19
21	DS27-123	SMV BRACKET - ND	1	49	FB50-082	#35 x 112 PITCH CHAIN	1	77	HW41005008SS	5/32 X 1/8 - 1/4 RIVETS SS	18
22	DS27-202	WIRE WRAP	2	50	HW01008048G5ZPC	1/4 X 1 1/2 HHCS	1	78	HW42010048G5ZP	5/16" x 1 1/2" Roll Pin Zinc Plated	3
23	DS27-216	CONTROLLER PLATE DS HYD.	1	51	HW01008072G5ZPC	1/4 X 2 1/4 HHCS	3	79	HW6003204810GZP	1" ID x 1 1/2" OD 10GA Machine Bushing	2
24	DS50-001	TOGGLE LATCH	6	52	HW01010024G5ZPC	5/16 X 3/4 HHCS	13	80	HW62#08010ZP	#8 x 5/16 THREAD FORMING SCREW	4
25	DS50-003	TOGGLE LATCH RETAINING PIN	6	53	HW01010048G5ZPC	5/16 x 1 1/2 Hex Head Cap Screw	8	81	ND50-035	1st PRODUCTS DECAL - LONG - SPING 2020	2
26	DS50-044	ADJUSTER DECAL	1	54	HW01012032G5ZPC	3/8 X 1 HHCS	8	82	UA50-007	3/16 LYNCH PIN	3
27	DS50-045	ND-144 QUICK CHART DECAL	1	55	HW01012048G5ZPC	3/8 X 1 1/2 HHCS	9	83	UA50-012	UA BELT COVER DECAL	1
28	DS50-051	3/4" ID LOOP CLAMP	1	56	HW01012064G5ZPC	3/8 X 2 HHCS	1	84	UA50-180	USA FLAG DECAL	1

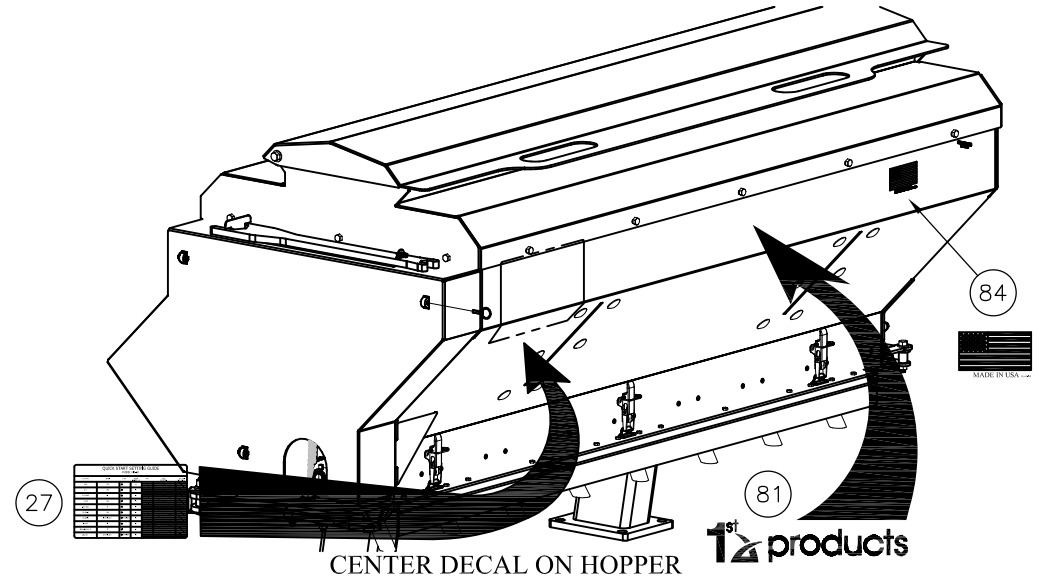
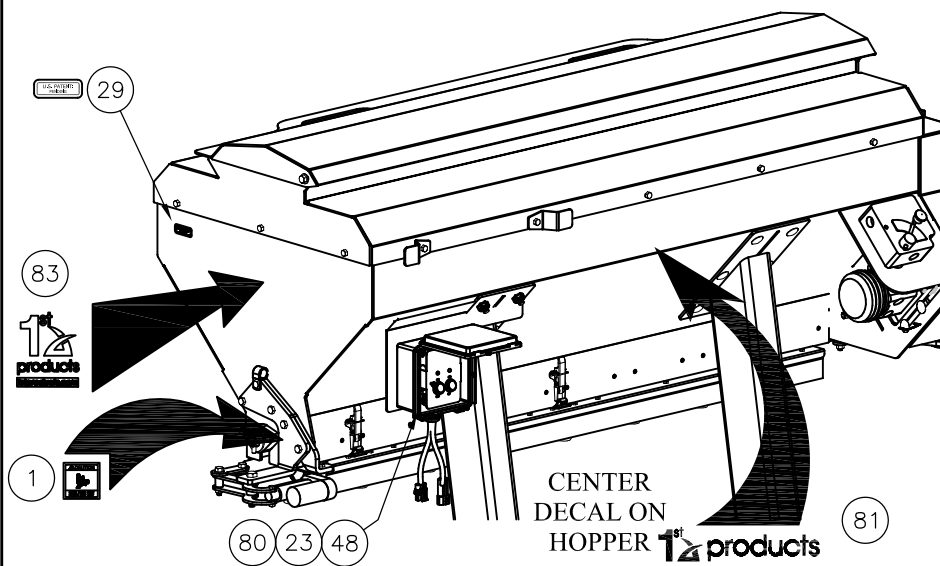

PRIMARY HOPPER GROUP

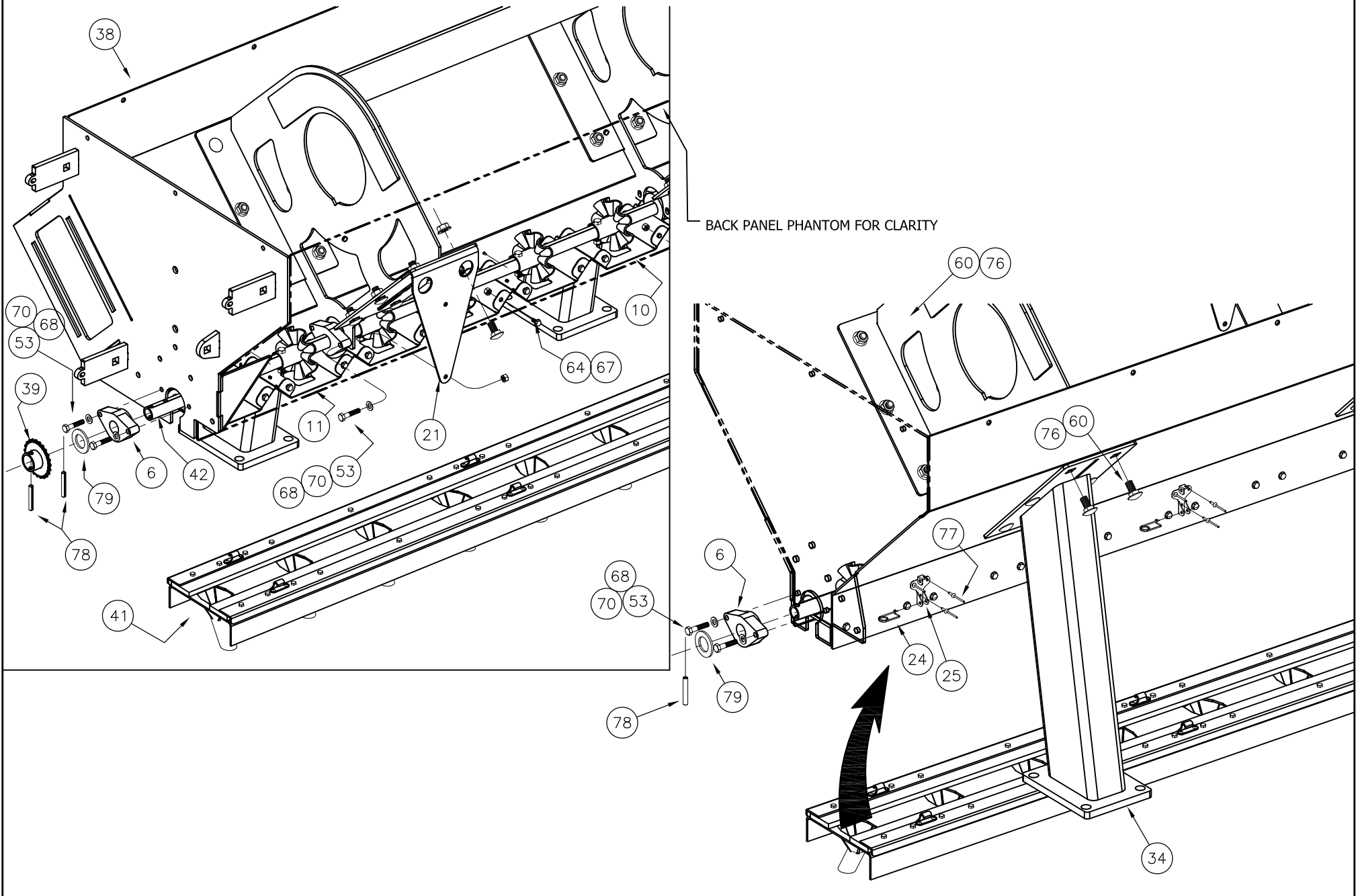

PRIMARY HOPPER GROUP

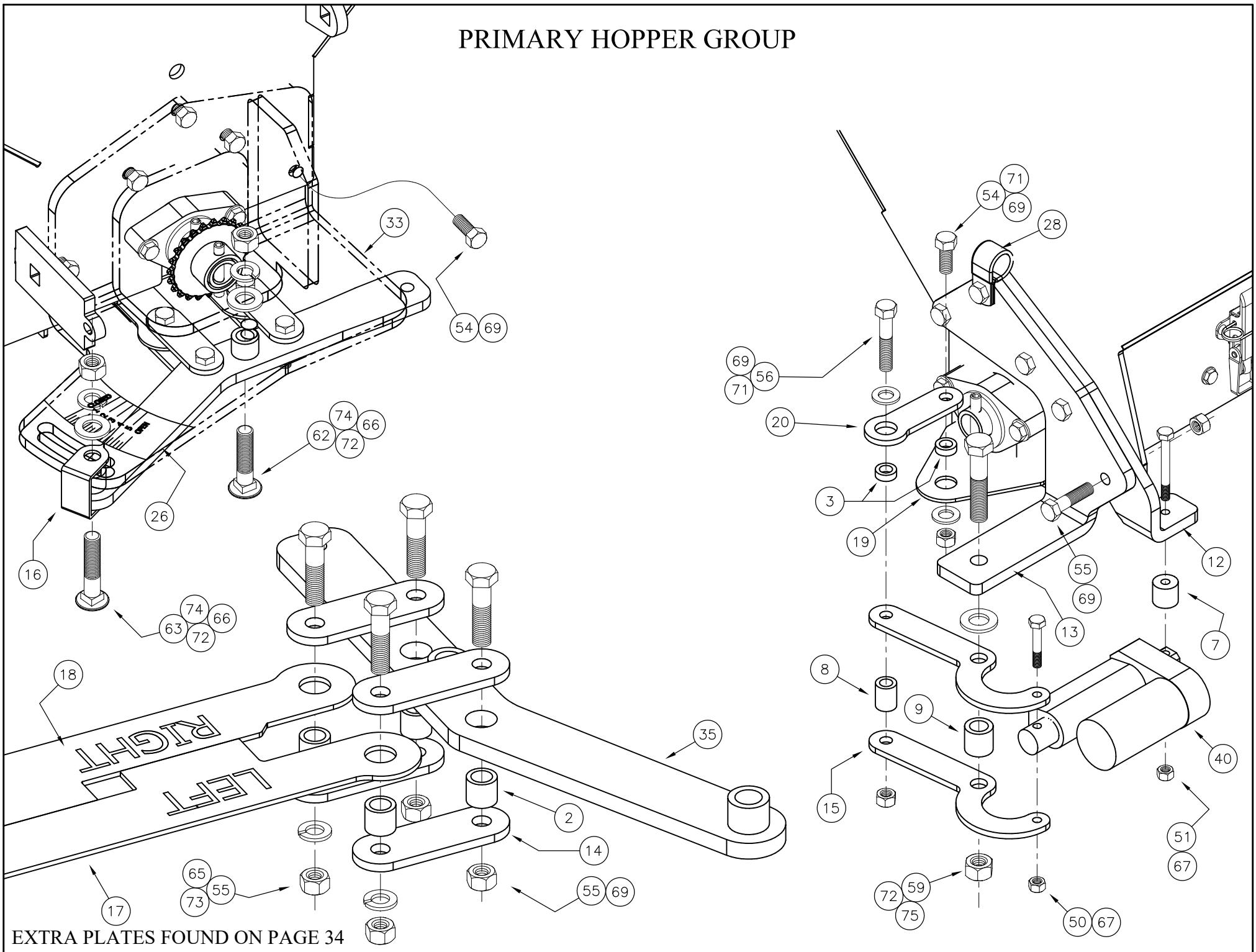

EXTRA PLATES FOUND ON PAGE 34

PRIMARY HOPPER GROUP

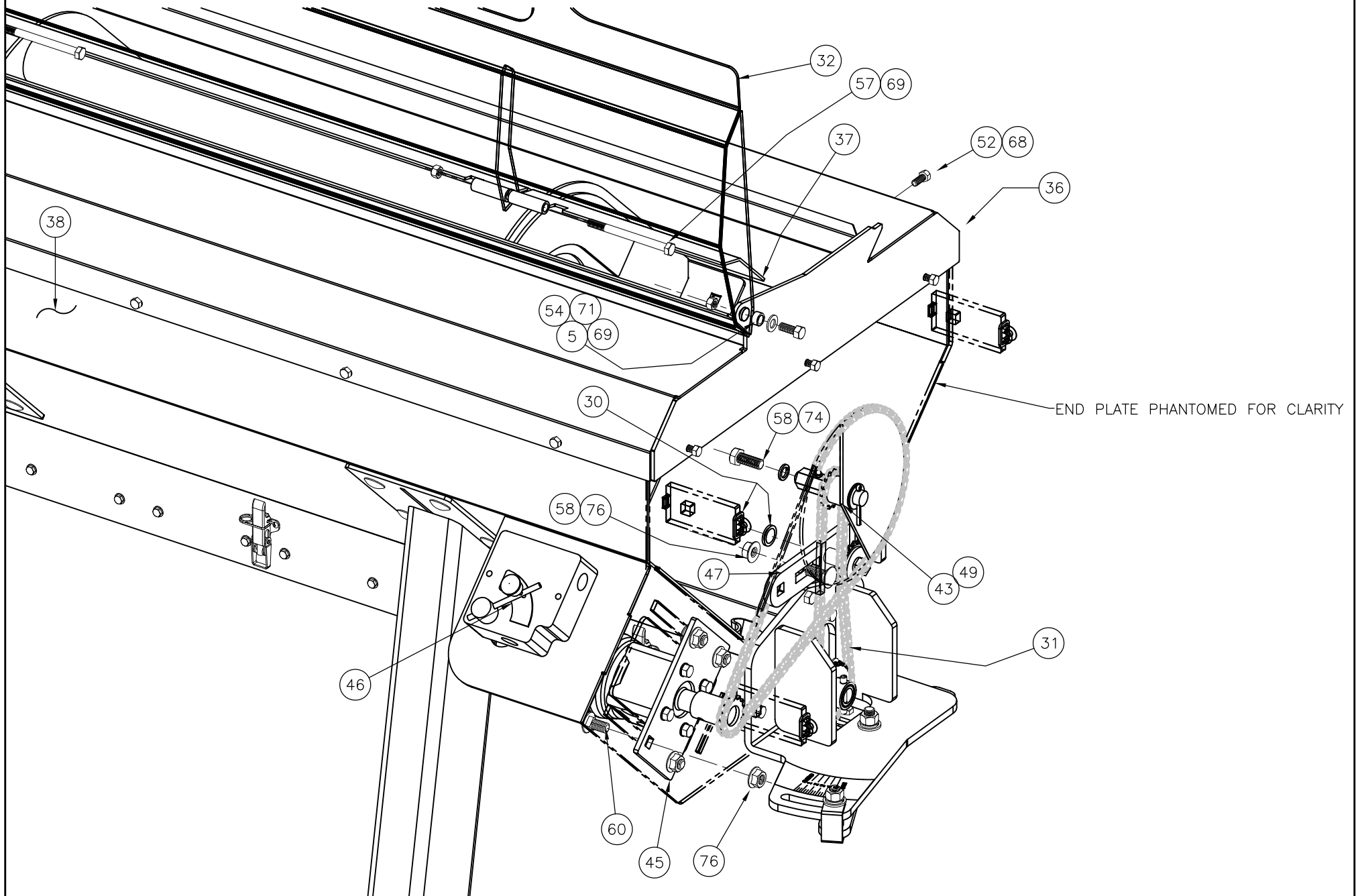

PRIMARY HOPPER (RT) GROUP

ITEM	PART NO	DESCRIPTION	QTY	ITEM	PART NO	DESCRIPTION	QTY	ITEM	PART NO	DESCRIPTION	QTY
1	DS24-004	METER PLATE BUSHINGS	4	23	DS80-003	DS-72 LID	1	45	HW06008016G5ZPC	1/4 X 1/2 FLANGE LOCK SCREW	32
2	DS24-011	CUT OFF PLATE BUSHINGS	2	24	DS80-006	Meter Adj. Bracket	1	46	HW20012G5ZPC	3/8 HEX NUT	2
3	DS24-028	LID BUSHING	2	25	DS80-009	SEEDBOX MOUNT	2	47	HW20016G5ZPC	1/2 HEX NUT	2
4	DS26-001	AGITATOR SHAFT BEARING	2	26	DS80-035	METER ADJUSTER	1	48	HW24008GBZPC	1/4 Stover Lock Nut	34
5	DS26-003	ACTUATOR SPACER 1	1	27	DS80-051	DS-72 CAP	1	49	HW24010GBZPC	5/16 Stover Lock Nut	24
6	DS26-004	ACTUATOR SPACER 2	1	28	DS80-053	DS-72 SPLASH GUARD	1	50	HW24012GBZPC	3/8 Stover Lock Nut	18
7	DS26-005	ACTUATOR SPACER 3	1	29	DS80-057	PRIMARY HOPPER - DS72 RT	1	51	HW31010TAZP	5/16 SAE Flat Washer	8
8	DS27-012	SEED FUNNEL 1	6	30	DS81-005	ACTUATOR ASSEMBLY	1	52	HW31012TAZP	3/8 SAE FLATWASHER	4
9	DS27-013	SEED FUNNEL 2	2	31	DS81-052	SPOUT TRAY - DS72	1	53	HW31016TAZP	1/2 SAE FLATWASHER	3
10	DS27-020	Actuator Mount	1	32	DS81-053	AGITATOR - DS72	1	54	HW32012G5ZP	3/8 LOCKWASHER	2
11	DS27-021	Actuator Linkage Pivot	1	33	HW01008048G5ZPC	1/4 X 1 1/2 HHCS	1	55	HW32016G5ZP	1/2 LOCK WASHER	2
12	DS27-022	METER PLATE LINKAGES	4	34	HW01008072G5ZPC	1/4 X 2 1/4 HHCS	1	56	HW34016G5ZPC	1/2 2-WAY LOCKUT	1
13	DS27-024	CUT OFF PLATE LEVER ACTION	2	35	HW01010024G5ZPC	5/16 X 3/4 HHCS	16	57	HW35016G5ZPC	1/2 FLANGE STOVER LOCKNUT	24
14	DS27-027	METER SCALE POINTER	1	36	HW01010048G5ZPC	5/16 x 1 1/2 Hex Head Cap Screw	8	58	HW41005008SS	5/32 X 1/8 - 1/4 RIVETS SS	18
15	DS27-034	LEFT SEED PLATE 3/4"	1	37	HW01012032G5ZPC	3/8 X 1 HHCS	8	59	HW42010048G5ZP	5/16" x 1 1/2" Roll Pin Zinc Plated	2
16	DS27-035	RIGHT SEED PLATE 3/4"	1	38	HW01012048G5ZPC	3/8 X 1 1/2 HHCS	9	60	HW6003204810GZP	1" ID x 1 1/2" OD 10GA Machine Bushing	2
17	DS27-044	CUT OFF PLATE	1	39	HW01012064G5ZPC	3/8 X 2 HHCS	1	61	ND50-035	1st PRODUCTS DECAL - LONG - SPING 2020	2
18	DS27-083	CUT OFF PLATE BUSHING LINKAGE	1	40	HW01012144G5ZPC	3/8 X 4 1/2 HHCS	2	62	UA50-012	UA BELT COVER DECAL	1
19	DS50-001	TOGGLE LATCH	6	41	HW01016080G5ZPC	1/2 X 2 1/2 HHCS	1				
20	DS50-003	TOGGLE LATCH RETAINING PIN	6	42	HW03016032G5PCS	1/2 X 1 Carriage Bolt	24				
21	DS50-044	ADJUSTER DECAL	1	43	HW03016072G5ZPC	1/2 x 2 1/4 CARRIAGE BOLT	1				
22	DS50-053	12 FT ACTUATOR HARNESS	1	44	HW03016080G5ZPC	1/2 X 2 1/2 CARRIAGE BOLT	1				

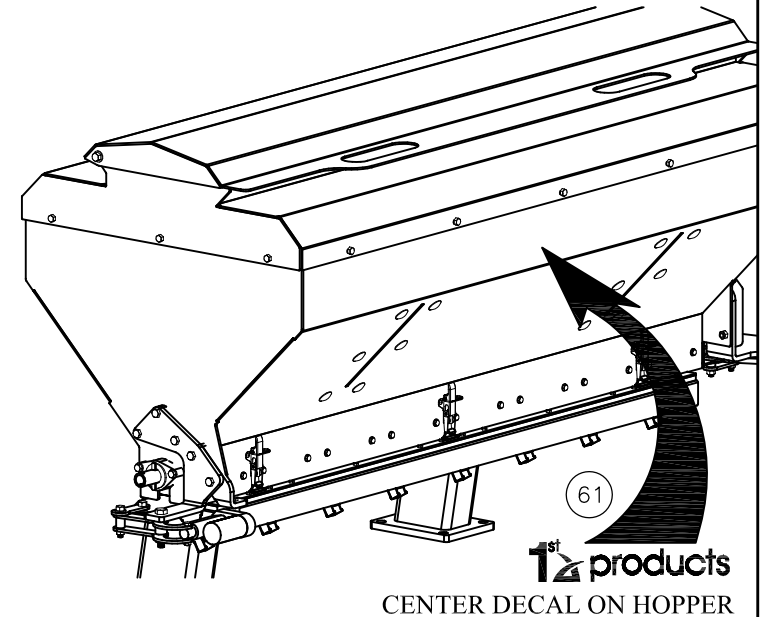
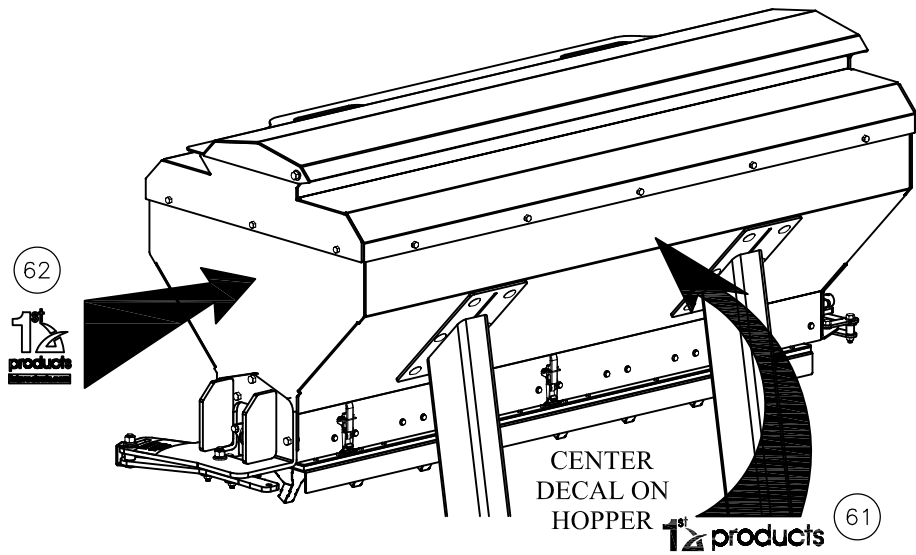

PRIMARY HOPPER (RT) GROUP

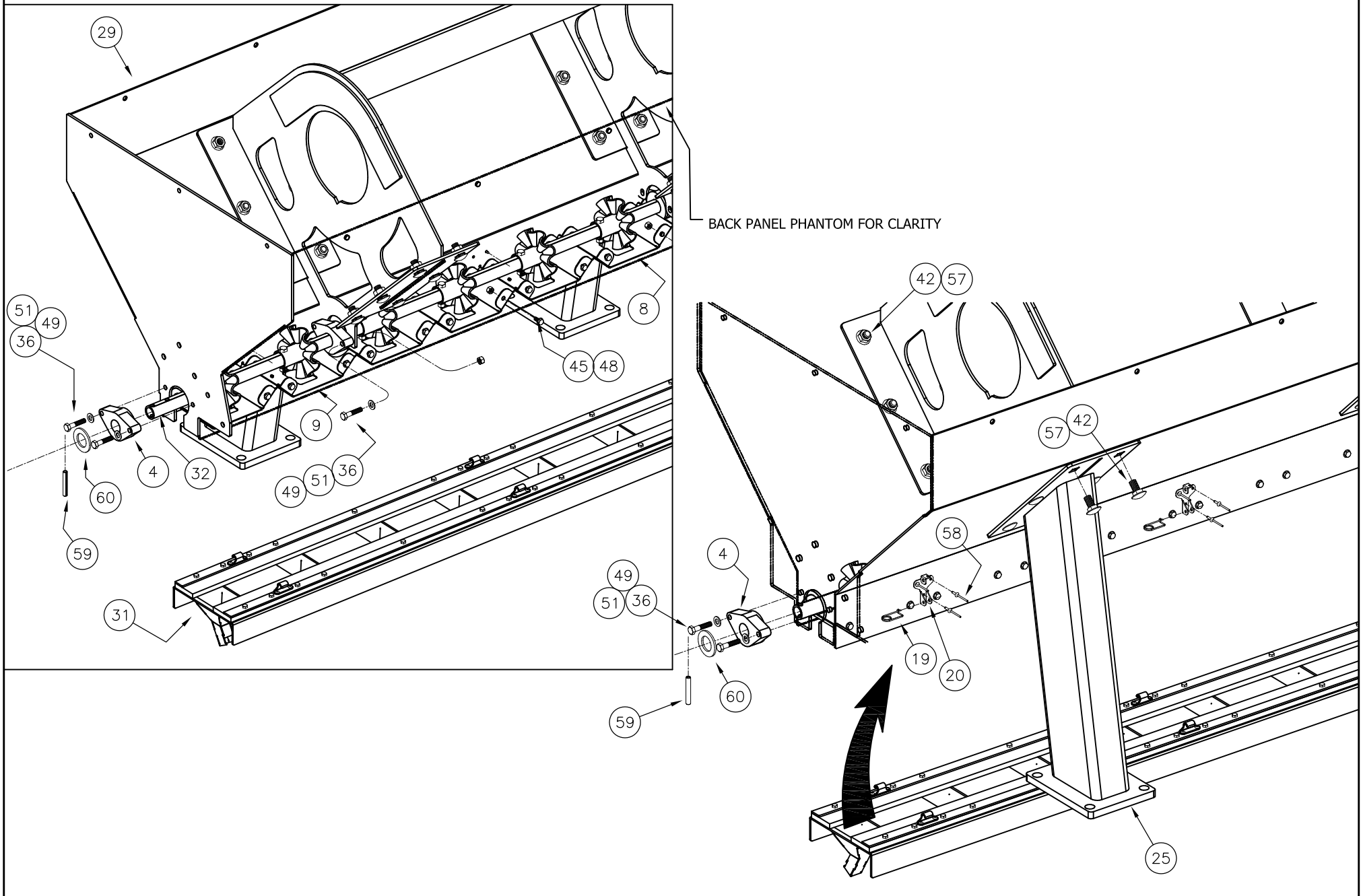

PRIMARY HOPPER (RT) GROUP

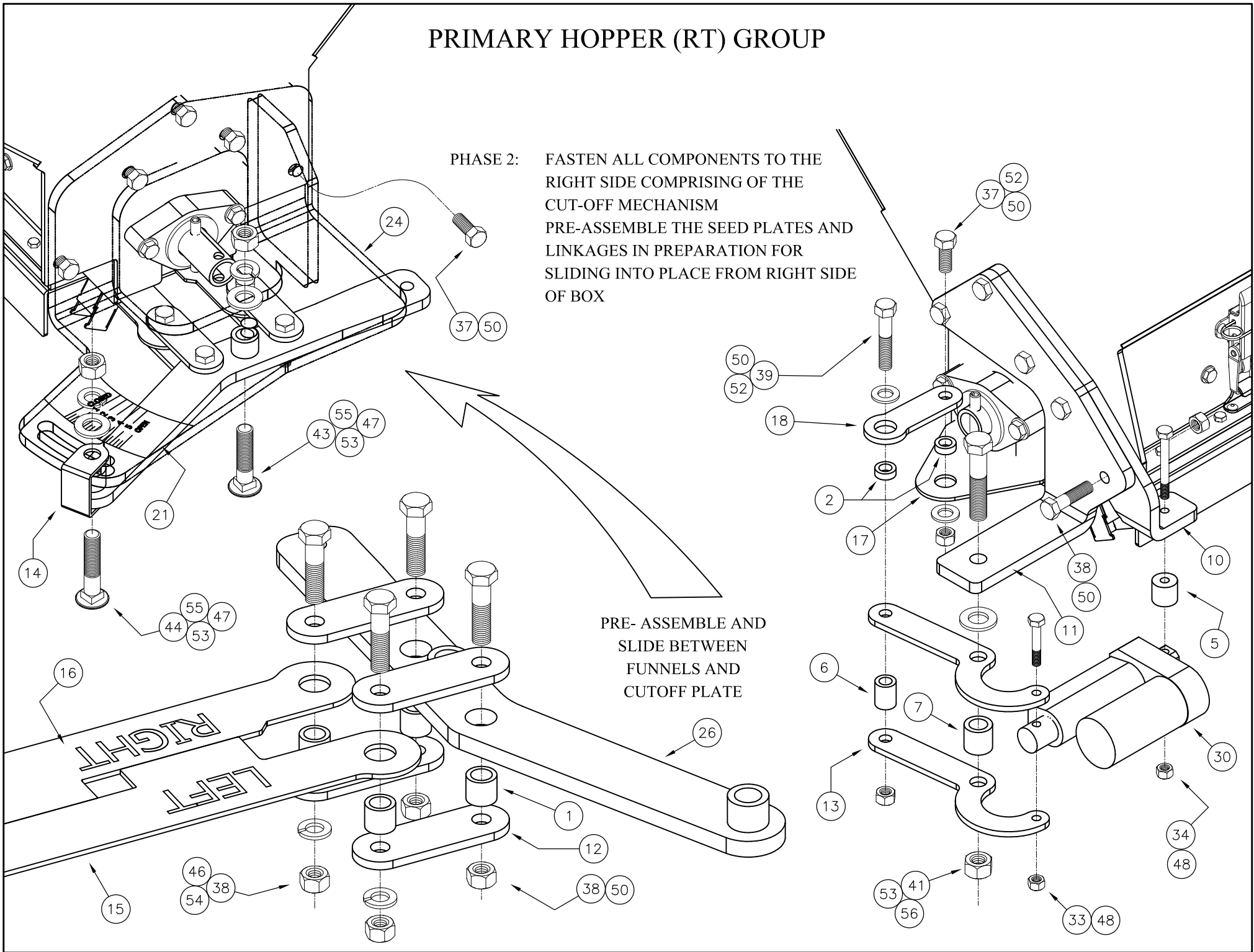

PRIMARY HOPPER (RT) GROUP

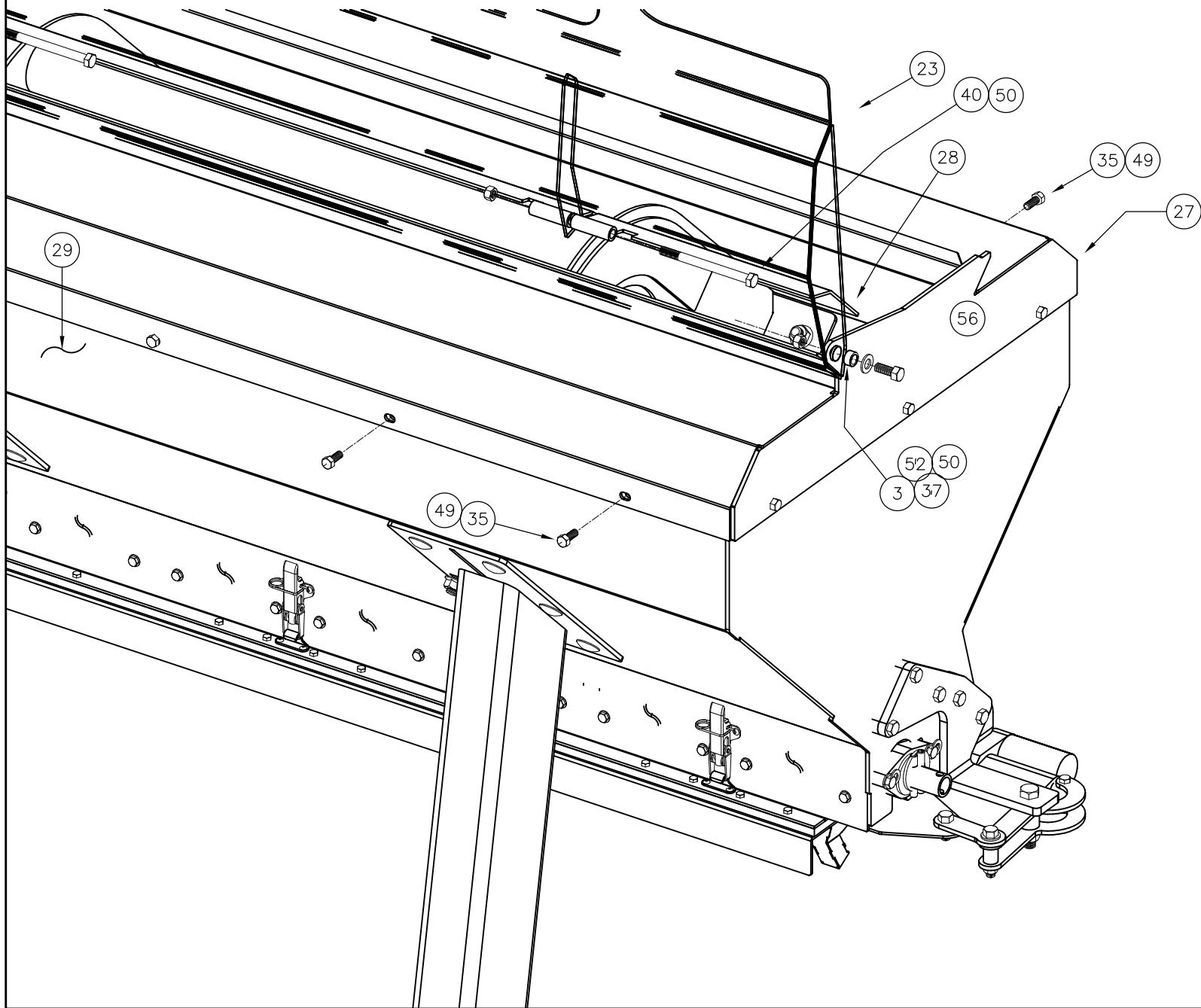

AGITATOR GROUP

ITEM	PART NO	DESCRIPTION	QTY
1	HW01010056G5ZPC	5/16 1 3/4 HHCS	8
2	HW24010GBZPC	5/16 STOVER LOCKNUT	8
3	DS80-010	AGITATOR	8
4	DS24-021	AGITATOR SHAFT - DS72	1
5	DS26-001	AGITATOR SHAFT BEARING	2

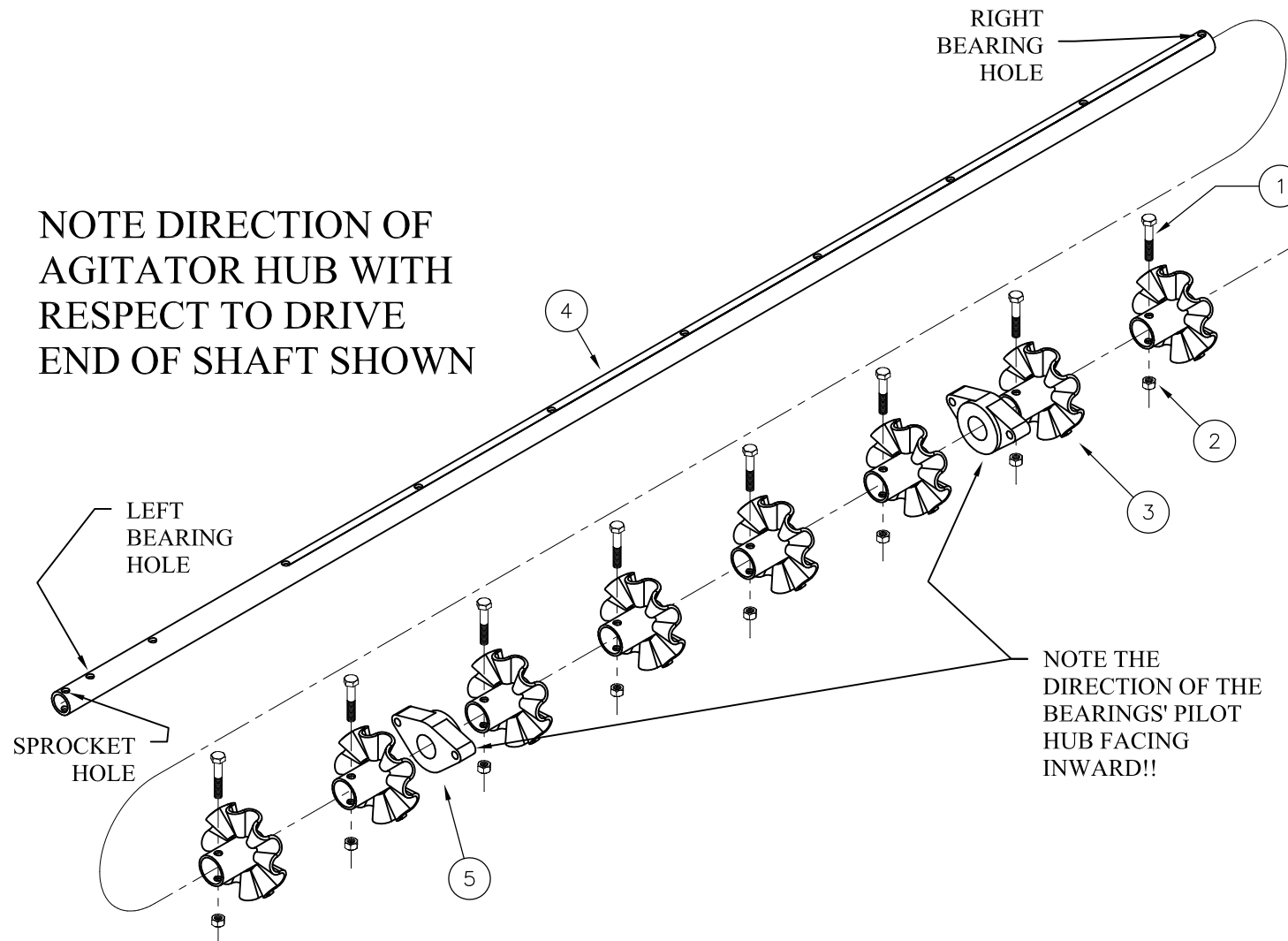

SPOUT TRAY GROUP

ITEM	PART NO	DESCRIPTION	QTY
1	DS26-002	8 OUTLET CUT OFF PLATE SLIDE	2
2	DS27-019	8 OUTLET CATCH PLATE SLIDE	2
3	DS50-002	TOGGLE LATCH PLATE	6
4	DS80-007	8 OUTLET SPOUT WELDMENT	1
5	HW01008032G5ZPC	1/4 X 1 HHCS	28
6	HW22008G5ZPC	1/4 FLANGE LOCK NUT	28
7	HW41005008SS	5/32 X 1/8-1/4 RIVET SS	12

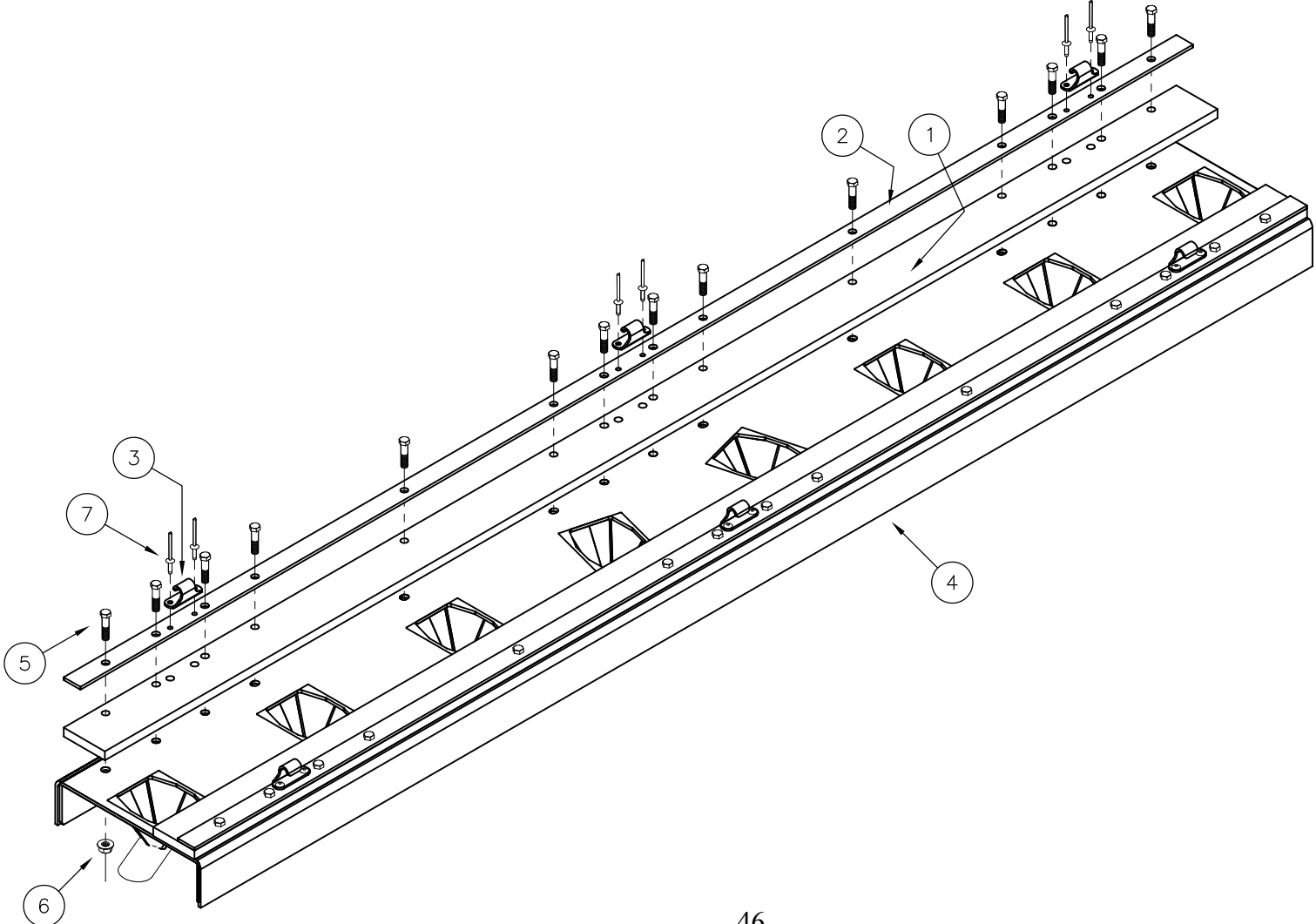

HYDRAULIC IDLER GROUP

ITEM	PART NO	DESCRIPTION	QTY
1	DS24-029	HYD. IDLER SPACERS	1
2	DS27-203	HYD. IDLER BASE PLATE	1
3	DS50-097	18 TOOTH #35 CHAIN IDLER SPROCKET	1
4	HW10016080G5ZPC	1/2" x 2-1/2" 82 DEG FLAT SOCKET HD. CAPSCREW	1
5	HW34016G5ZPC	1/2" 2-WAY LOCK NUT	1

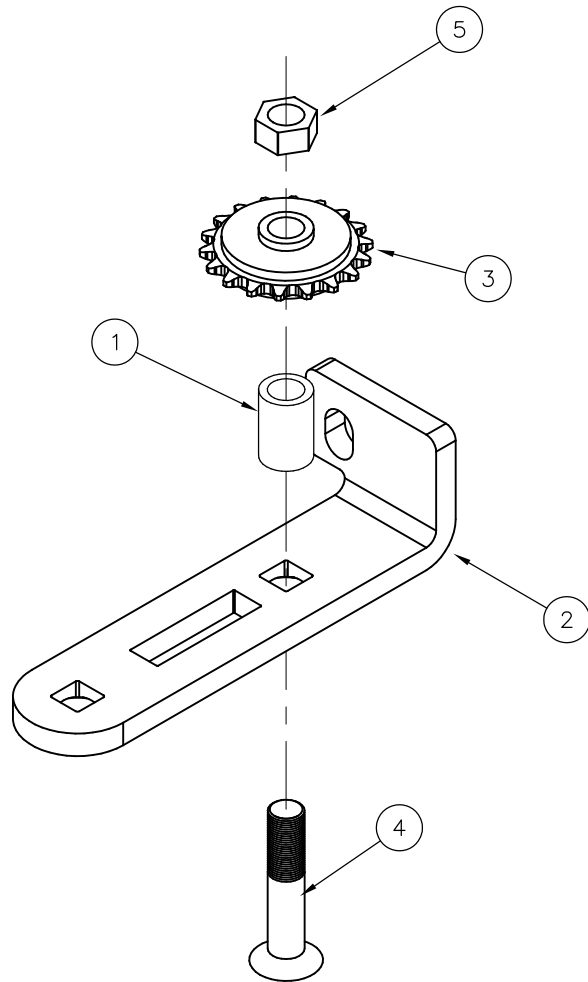

HYDRAULIC MOTOR GROUP

ITEM	PART NO	DESCRIPTION	QTY
1	DS27-056	DS HYD. MOTOR SLIDE	1
2	DS50-101	ADAPTER, 1/2 MNPT x #8MJIC	2
3	FB50-061	HYDRAULIC MOTOR	1
4	WB50-211	ADAPTER, RUN TEE, #8JIC	1
5	HW01012032G5ZPC	3/8" x 1" HHCS	4
6	HW32012G5ZPC	3/8" LOCK WASHER	4
7	DS80-077	DS HYD. DRIVE MOTOR SPKT. HUB	1
8	HW42010040G5ZPC	5/16" x 1-1/2" ROLL PIN ZINC PLATED	1

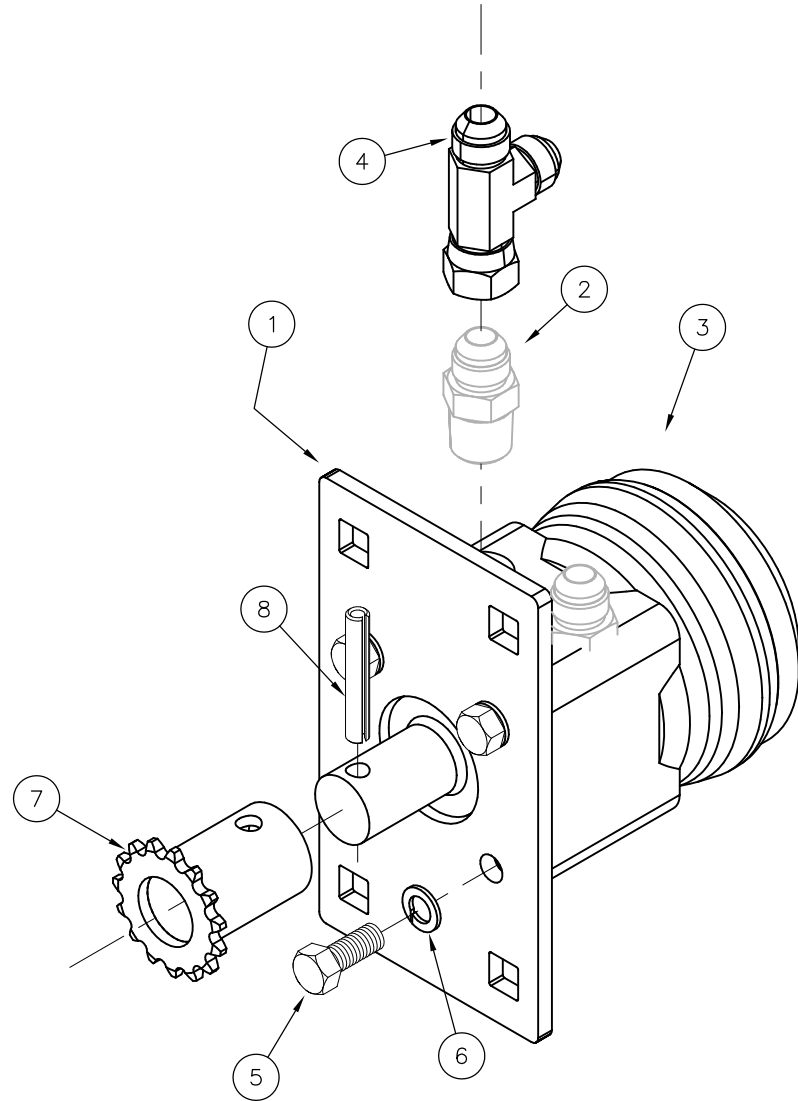

HYDRAULIC FLOW CONTROL GROUP

ITEM	PART NO	DESCRIPTION	QTY
1	DS50-095	DS HYD. FLOW CONTROL 0-8 GPM	1
2	FB50-072	1/2" BALL VALVE	1
3	DS50-098	ADAPTER, 3/8" MNPT to 1/2" FNPT, SWIVEL 90	1
4	DS50-100	ADAPTER, 3/8" MNPT x #8 MJIC	2
5	DS50-101	ADAPTER, 1/2" MNPT x #8 MJIC	1
6	DS50-102	1/2" MALE NIPPLE	1

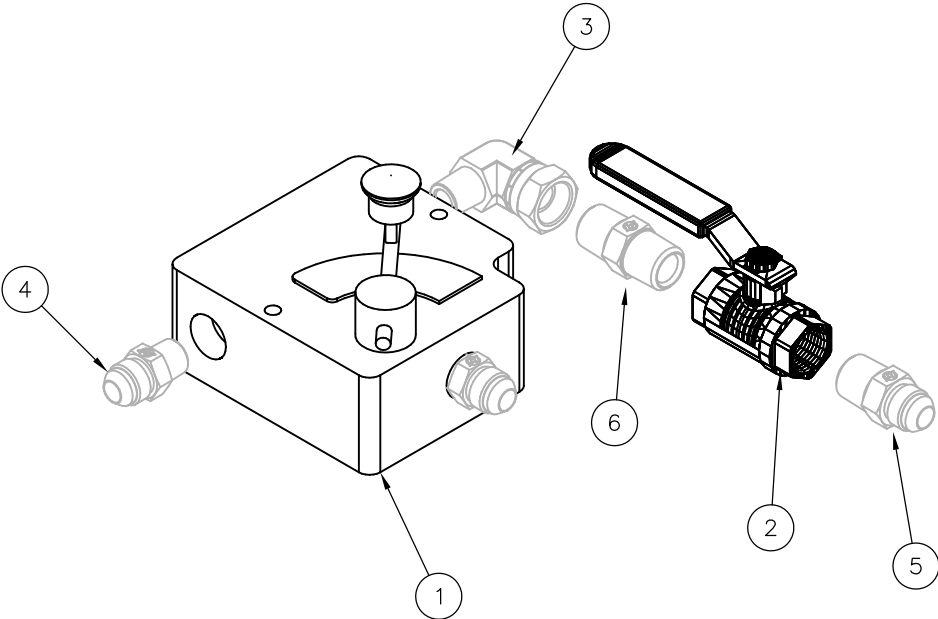

PRIMARY HOPPER HYDRAULICS GROUP

ITEM#	PART NO.	DESCRIPTION	QTY
1	DS50-095	DS HYD. FLOW CONTROL 0.8 GPM	1
2	DS50-098	ADAPTER, #8 MJC X 3/8" MNPT 90 ELBOW	1
3	DS50-100	ADAPTER, 3/8" MNPT X #8 MJC	2
4	DS50-101	ADAPTER, 1/2" MNPT X #8 MJC	4
5	DS50-104	ADAPTER, #8 MJC X #8 MJC, 90 DEG	2
6	DS50-106	HYD HOSE A	2
7	DS50-107	HYD HOSE B	2
8	DS50-108	HYD HOSE C	1
9	DS50-109	HYD HOSE D	1
10	DS50-110	SINGLE DIRECTION FLOW MALE TIP	1
11	DS50-130	ADAPTER, #10 MJC X #12 MSAE	1
12	DS50-131	ADAPTER, #8 MJC X #12 MSAE 90	1
13	DS50-132	ADAPTER, #10 MJC X #10 MJC STRT	2
14	DS50-134	HOSE, FLOW DIVIDER TO INLET FC	1
15	DS50-135	HOSE, TEE TO TEE MOTOR	1
16	FA50-068	QUICK COUPLER	1
17	FBS50-061	HYDRAULIC MOTOR	1
18	ND50-158	ADAPTER, #8 MORB - 1/2" FFS	1
19	ND50-160	REDUCER ADAPTER, #10 FFC X #8 MJC	2
20	WB50-211	ADAPTER, RUN TEE, #8 MJC	1
21	DS50-124	ADAPTER, #10 MJC TEE	1
22	DS50-121	ADAPTER, #8 MJC X #12 MORB	1
23	DS50-133	HYD PRESSURE HOSE EXTENTION	1
24	DS50-093	LFPH EXTENSION HARNESS	1
25	DS50-120	DS HYD FLOW DIVIDER	1

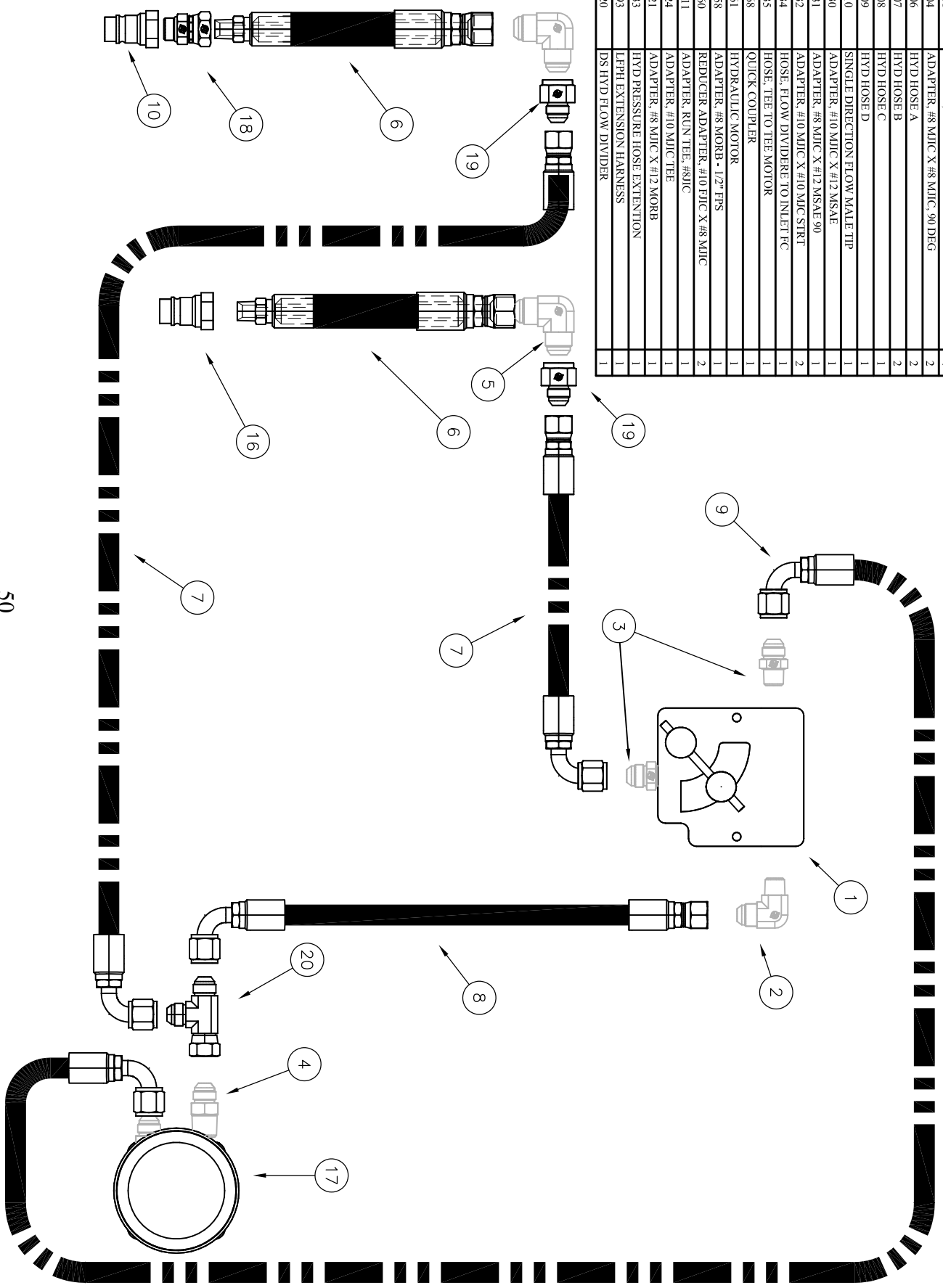

PRIMARY & AUXILIARY HOPPER HYDRAULICS GROUP

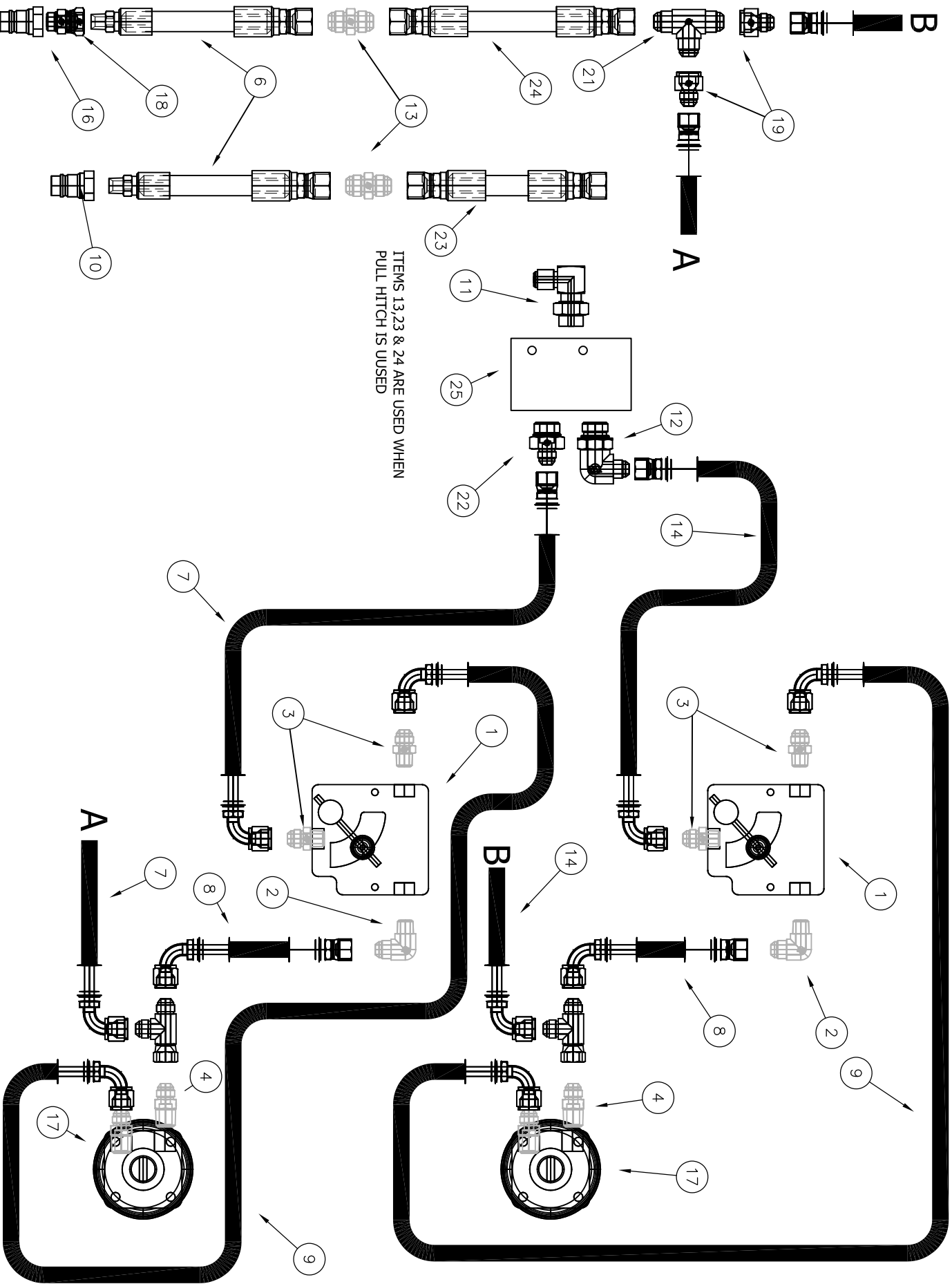

AUXILIARY HOPPER GROUP

ITEM	PART NO	DESCRIPTION	QTY	ITEM	PART NO	DESCRIPTION	QTY	ITEM	PART NO	DESCRIPTION	QTY
1	AE50-075	PINCH POINT CAUTION DECAL	1	27	DS50-119	#35 x 84 PITCH CHAIN	1	53	HW01016080G5ZPC	1/2 X 2 1/2 HHCS ALL THREAD	2
2	DS24-004	METER PLATE BUSHINGS	4	28	ND50-035	1st PRODUCTS DECAL - LONG - SPING 2020	1	54	HW01016160G5ZPC	1/2 X 5 HHCS	2
3	DS24-011	CUT OFF PLATE BUSHINGS	2	29	SB50-053	T-HANDLE DRAW LATCH	1	55	HW03016040G5ZPC	1/2 x 1-1/4 CARRIAGE BOLT	5
4	DS24-016	IDLER SPACERS	4	30	UA50-007	3/16 LYNCH PIN	2	56	HW03016072G5ZPC	1/2 x 2 1/4 CARRIAGE BOLT	1
5	DS24-028	LID BUSHING	2	31	UA50-180	USA FLAG DECAL	1	57	HW03016080G5ZPC	1/2 X 2 1/2 CARRIAGE BOLT	1
6	DS26-001	AGITATOR SHAFT BEARING	2	32	DS80-006	Meter Adj. Bracket	1	58	HW06008016G5ZPC	1/4 X 1/2 FLANGE LOCK SCREW	32
7	DS26-003	ACTUATOR SPACER 1	1	33	DS80-027	SMALL BOX CHAIN COVER	1	59	HW06008024G5ZPF	1/4 X 3/4 HEX FLG LK SC. FINE	4
8	DS26-004	ACTUATOR SPACER 2	1	34	DS80-035	METER ADJUSTER	1	60	HW20012G5ZPC	3/8 HEX NUT	2
9	DS26-005	ACTUATOR SPACER 3	1	35	DS80-082	AGITATOR DRIVE SPKT. #35 CHAIN	1	61	HW20016G5ZPC	1/2 HEX NUT	3
10	DS27-012	SEED FUNNEL 1	8	36	DS80-081	DS-72 AUX. HOPPER HYD.	1	62	HW24008GBZPC	1/4 Stover Lock Nut	34
11	DS27-020	Actuator Mount	1	37	DS80-056	SMALL HOPPER LID - DS72	1	63	HW24010GBZPC	5/16 STOVER LOCK NUT	4
12	DS27-021	Actuator Linkage Pivot	1	38	DS81-005	ACTUATOR ASSEMBLY	1	64	HW24012GBZPC	3/8 Stover Lock Nut	16
13	DS27-022	METER PLATE LINKAGES	4	39	DS81-052	SPOUT TRAY - DS72	1	65	HW31010TAZP	5/16 SAE Flat Washer	4
14	DS27-024	CUT OFF PLATE LEVER ACTION	2	40	DS81-054	AGITATOR - DS72 (small box)	1	66	HW31012TAZP	3/8 SAE FLATWASHER	4
15	DS27-027	METER SCALE POINTER	1	41	DS81-074	DS HYD. REDUCTION ASSM.	1	67	HW31016TAZP	1/2 SAE FLATWASHER	7
16	DS27-083	CUT OFF PLATE BUSHING LINKAGE	1	42	DS81-080	DS HYD. MOTOR ASSM.	1	68	HW32012G5ZP	3/8 LOCKWASHER	2
17	DS27-044	CUT OFF PLATE	1	43	DS81-081	DS HYD. FLOW CONTROL ASSM.	1	69	HW32016G5ZP	1/2 LOCK WASHER	3
18	DS27-040	LEFT SEED PLATE 1/4"	1	44	DS81-083	DS HYD. AUXILLARY IDLER ASSEMBLY	1	70	HW34#10G5ZPC	#10 2-WAY LOCKNUT	4
19	DS27-041	RIGHT SEED PLATE 1/4"	1	45	DS81-085	DS HYD. CHAIN GAURD --AUX	1	71	HW34016G5ZPC	1/2 2-WAY LOCKUT	3
20	ND27-201	AB HYD. HOSE BRACKET	1	46	HW01008048G5ZPC	1/4 X 1 1/2 HHCS	1	72	HW35016G5ZPC	1/2 SMOOTH FLANGE STOVER	5
21	DS50-001	TOGGLE LATCH	6	47	HW01008072G5ZPC	1/4 X 2 1/4 HHCS	1	73	HW41005008SS	5/32 X 1/8 - 1/4 RIVETS SS	18
22	DS50-003	TOGGLE LATCH RETAINING PIN	6	48	HW01010048G5ZPC	5/16 x 1 1/2 Hex Head Cap Screw	4	74	HW41006008SS	3/16 X 1/16-1/8 RIVET	4
23	DS50-044	ADJUSTER DECAL	1	49	HW01012032G5ZPC	3/8 X 1 HHCS	8	75	HW42010048G5ZP	5/16" x 1 1/2" Roll Pin Zinc Plated	3
24	DS50-045	ND-144 QUICK CHART DECAL	1	50	HW01012048G5ZPC	3/8 X 1 1/2 HHCS	9	76	HW6003204810GZP	1" ID x 1 1/2" OD 10GA Machine Bushing	2
25	DS50-051	3/4" ID LOOP CLAMP	1	51	HW01012064G5ZPC	3/8 X 2 HHCS	1	77			1
26	DS50-118	#35 x 98 PITCH CHAIN	1	52	HW01016040G5ZPC	1/2 x 1-1/4 HHCS	1				

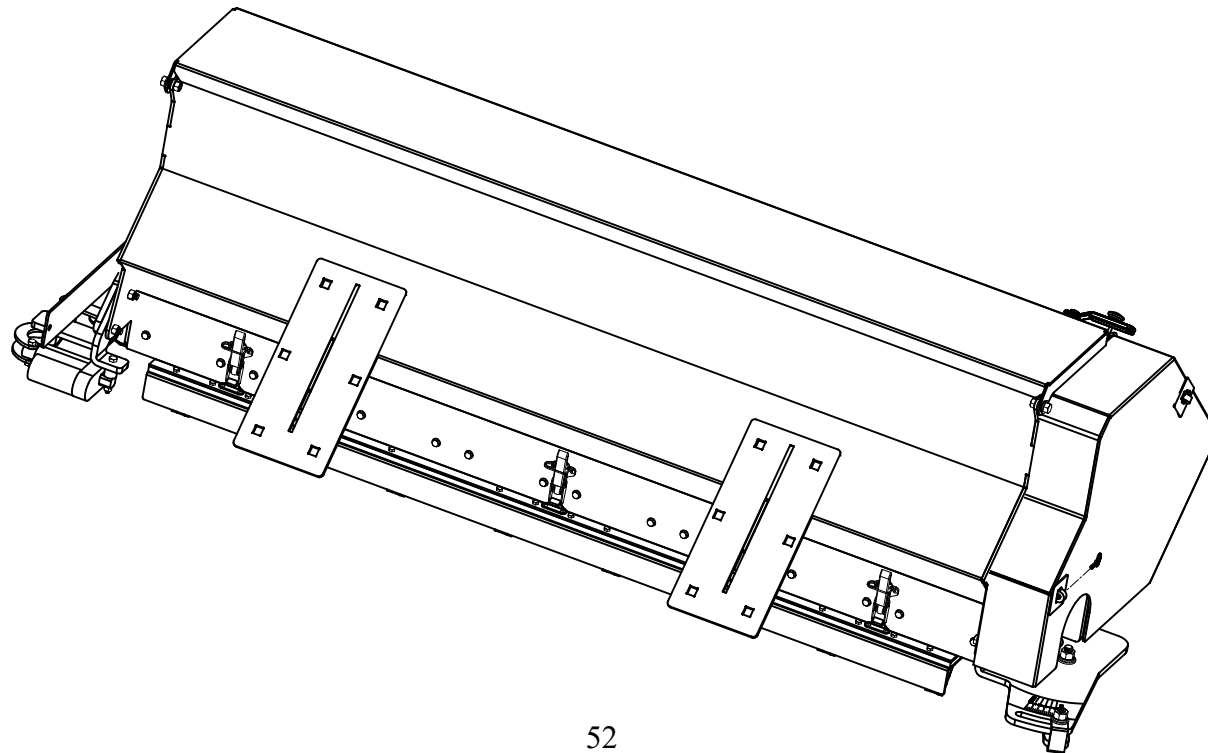

AUXILIARY HOPPER GROUP

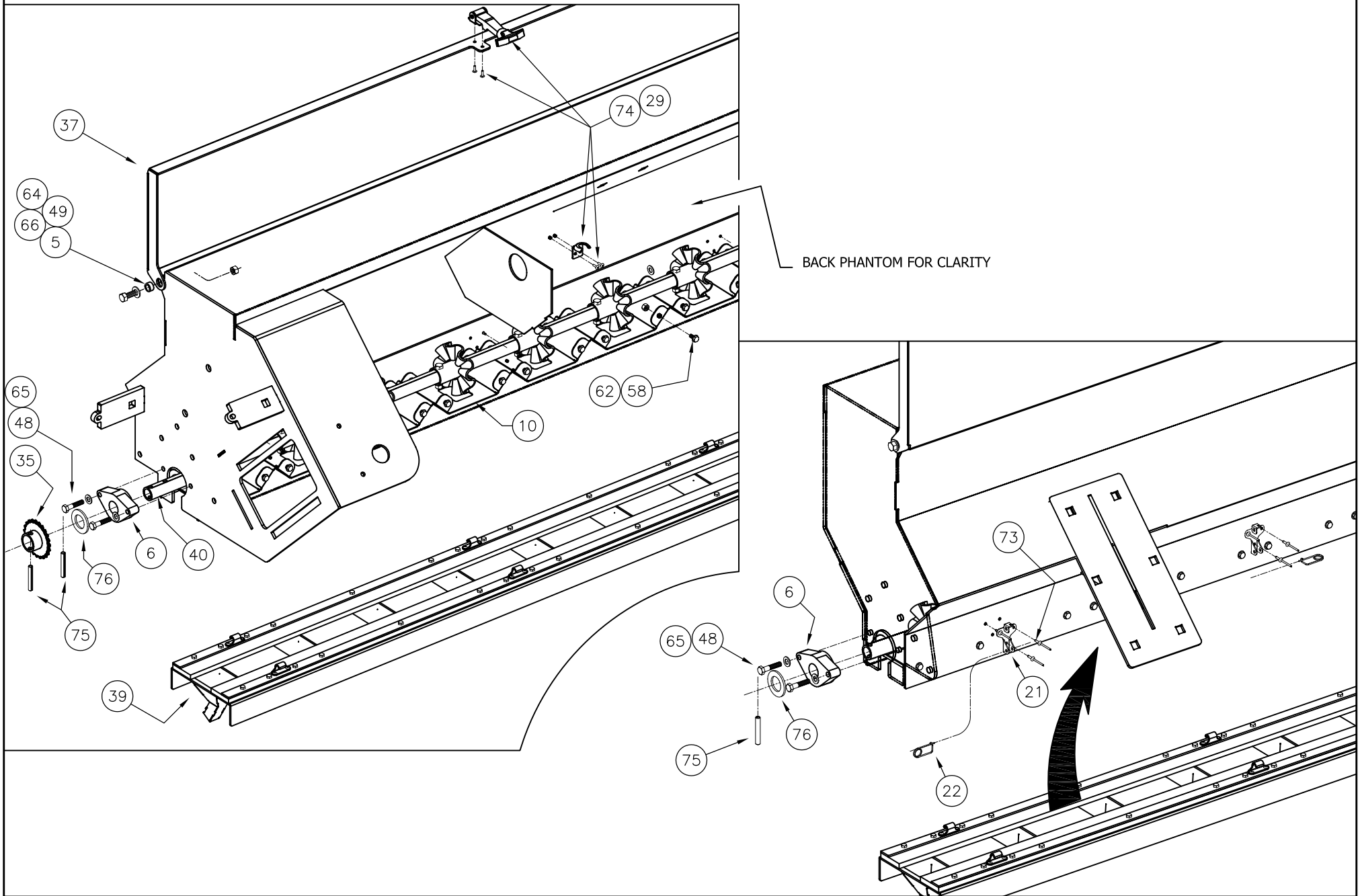

AUXILIARY HOPPER GROUP

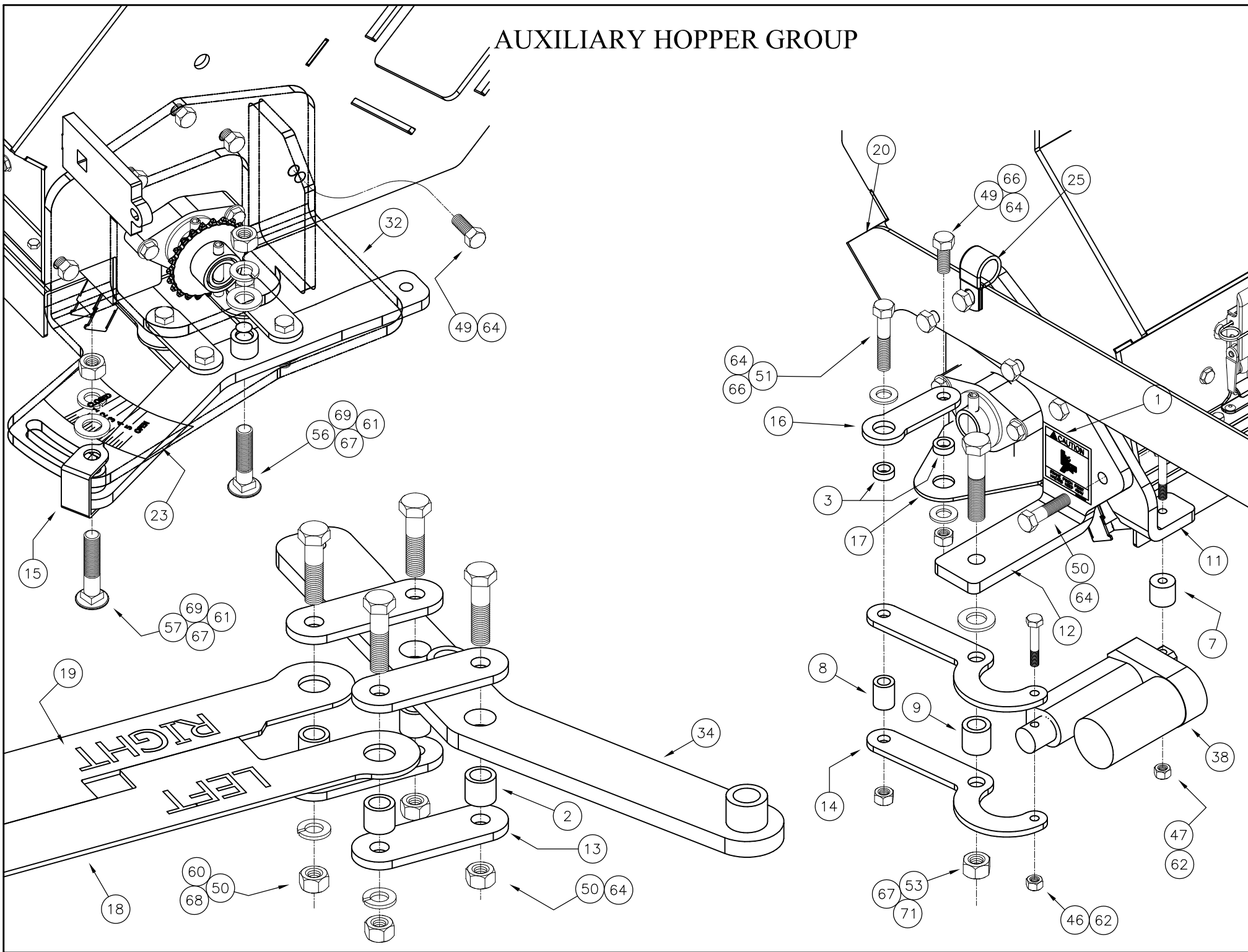

AUXILIARY HOPPER GROUP

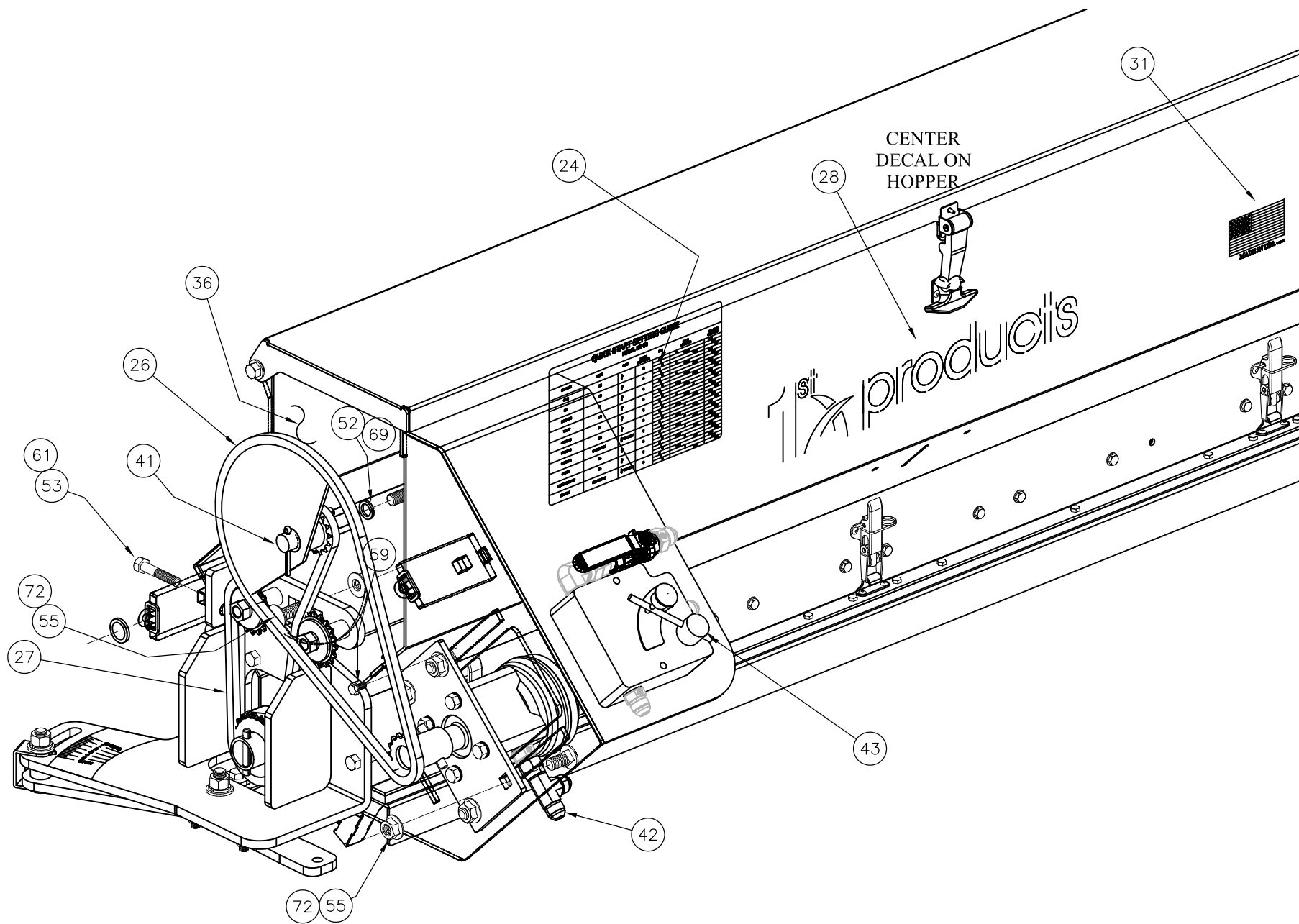

AUXILIARY HOPPER (RT) GROUP

ITEM	PART NO	DESCRIPTION	QTY	ITEM	PART NO	DESCRIPTION	QTY	ITEM	PART NO	DESCRIPTION	QTY
1	DS24-004	METER PLATE BUSHINGS	4	21	DS50-051	3/4" ID LOOP CLAMP	1	41	HW20016G5ZPC	1/2 HEX NUT	2
2	DS24-011	CUT OFF PLATE BUSHINGS	2	22	DS50-053	12FT ACTUATOR HARNESS	1	42	HW24008GBZPC	1/4 Stover Lock Nut	34
3	DS24-028	LID BUSHING	2	23	DS80-006	Meter Adj. Bracket	1	43	HW24010GBZPC	5/16 Stover Lock Nut	4
4	DS26-001	AGITATOR SHAFT BEARING	2	24	DS80-035	METER ADJUSTER	1	44	HW24012GBZPC	3/8 Stover Lock Nut	16
5	DS26-003	ACTUATOR SPACER 1	1	25	DS80-056	SMALL HOPPER LID - DS72	1	45	HW31010TAZP	5/16 SAE Flat Washer	4
6	DS26-004	ACTUATOR SPACER 2	1	26	DS80-058	DS-72 RT SMALL HOPPER	1	46	HW31012TAZP	3/8 SAE FLATWASHER	4
7	DS26-005	ACTUATOR SPACER 3	1	27	DS81-005	ACTUATOR ASSEMBLY	1	47	HW31016TAZP	1/2 SAE FLATWASHER	3
8	DS27-012	SEED FUNNEL 1	8	28	DS81-052	SPOUT TRAY - DS72	1	48	HW32012G5ZP	3/8 LOCKWASHER	2
9	DS27-020	Actuator Mount	1	29	DS81-054	AGITATOR - DS72 (small box)	1	49	HW32016G5ZP	1/2 LOCK WASHER	2
10	DS27-021	Actuator Linkage Pivot	1	30	HW01008048G5ZPC	1/4 X 1 1/2 HHCS	1	50	HW34016G5ZPC	1/2 2-WAY LOCKUT	1
11	DS27-022	METER PLATE LINKAGES	4	31	HW01008072G5ZPC	1/4 X 2 1/4 HHCS	1	51	HW41005008SS	5/32 X 1/8 - 1/4 RIVETS SS	18
12	DS27-024	CUT OFF PLATE LEVER ACTION	2	32	HW01010048G5ZPC	5/16 x 1 1/2 Hex Head Cap Screw	4	52	HW41006008SS	3/16 X 1/16-1/8 RIVET	4
13	DS27-027	METER SCALE POINTER	1	33	HW01012032G5ZPC	3/8 X 1 HHCS	8	53	HW42010048G5ZP	5/16" x 1 1/2" Roll Pin Zinc Plated	2
14	DS27-040	LEFT SEED PLATE 1/4"	1	34	HW01012048G5ZPC	3/8 X 1 1/2 HHCS	9	54	HW6003204810GZP	1" ID x 1 1/2" OD 10GA Machine Bushing	2
15	DS27-041	RIGHT SEED PLATE 1/4"	1	35	HW01012064G5ZPC	3/8 X 2 HHCS	1	55	ND50-035	1st PRODUCTS DECAL - LONG - SPING 2020	1
16	DS27-044	CUT OFF PLATE	1	36	HW01016080G5ZPC	1/2 X 2 1/2 HHCS	1	56	SB50-053	T-HANDLE DRAW LATCH	1
17	DS27-083	CUT OFF PLATE BUSHING LINKAGE	1	37	HW03016072G5ZPC	1/2 x 2 1/4 CARRIAGE BOLT	1				
18	DS50-001	TOGGLE LATCH	6	38	HW03016080G5ZPC	1/2 X 2 1/2 CARRIAGE BOLT	1				
19	DS50-003	TOGGLE LATCH RETAINING PIN	6	39	HW06008016G5ZPC	1/4 X 1/2 FLANGE LOCK SCREW	32				
20	DS50-044	ADJUSTER DECAL	1	40	HW20012G5ZPC	3/8 HEX NUT	2				

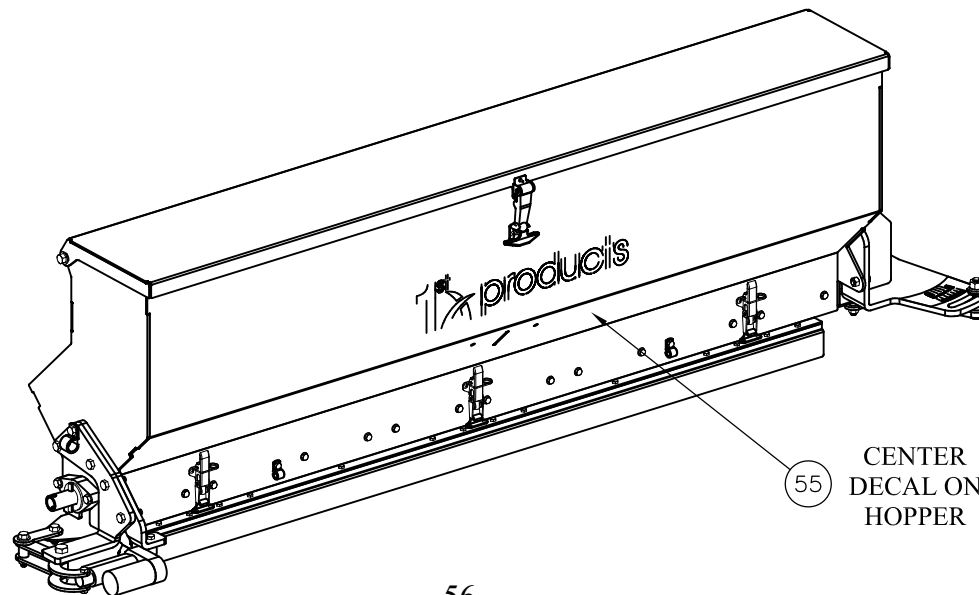

AUXILIARY HOPPER (RT) GROUP

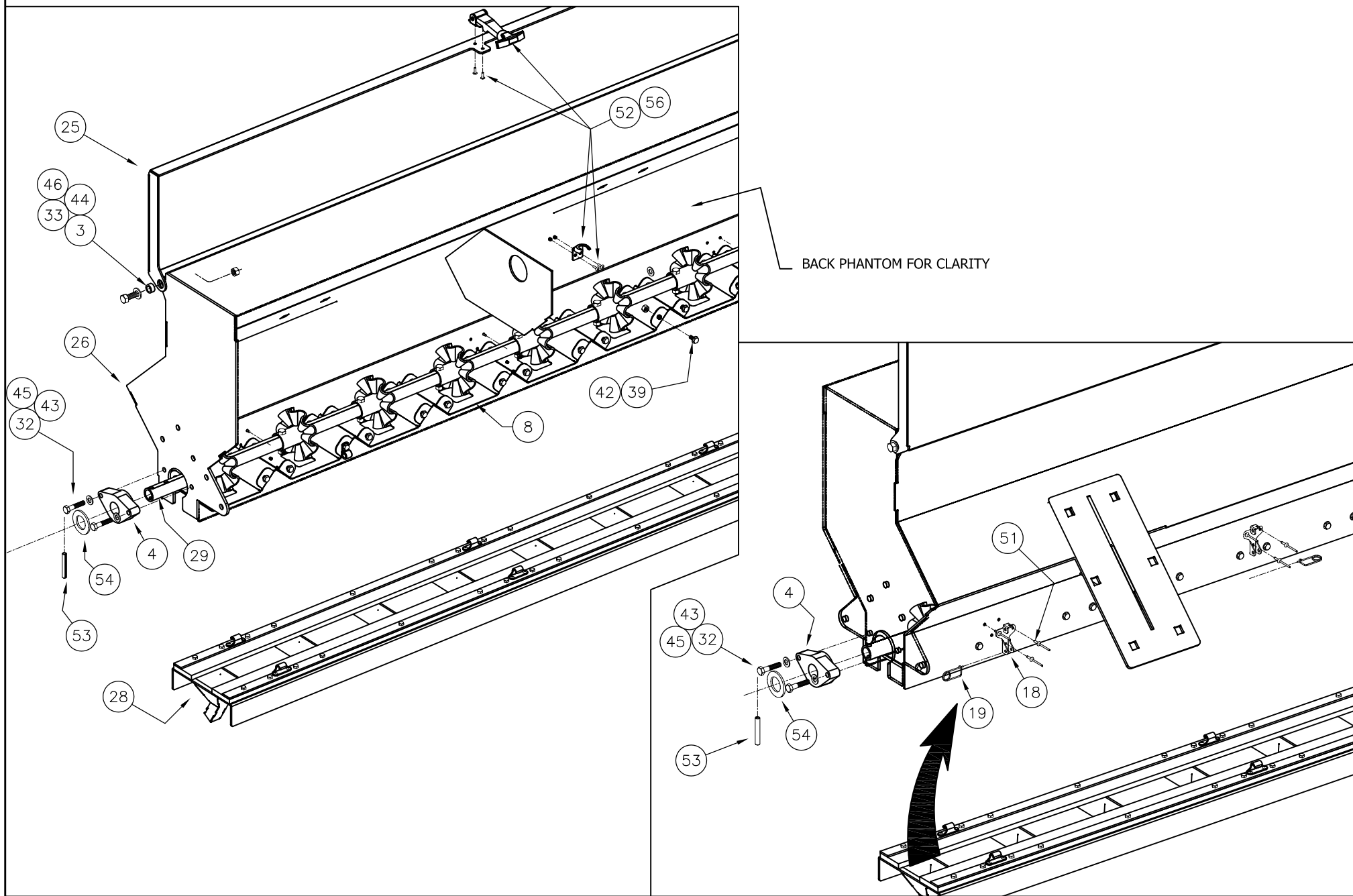

AUXILIARY HOPPER (RT) GROUP

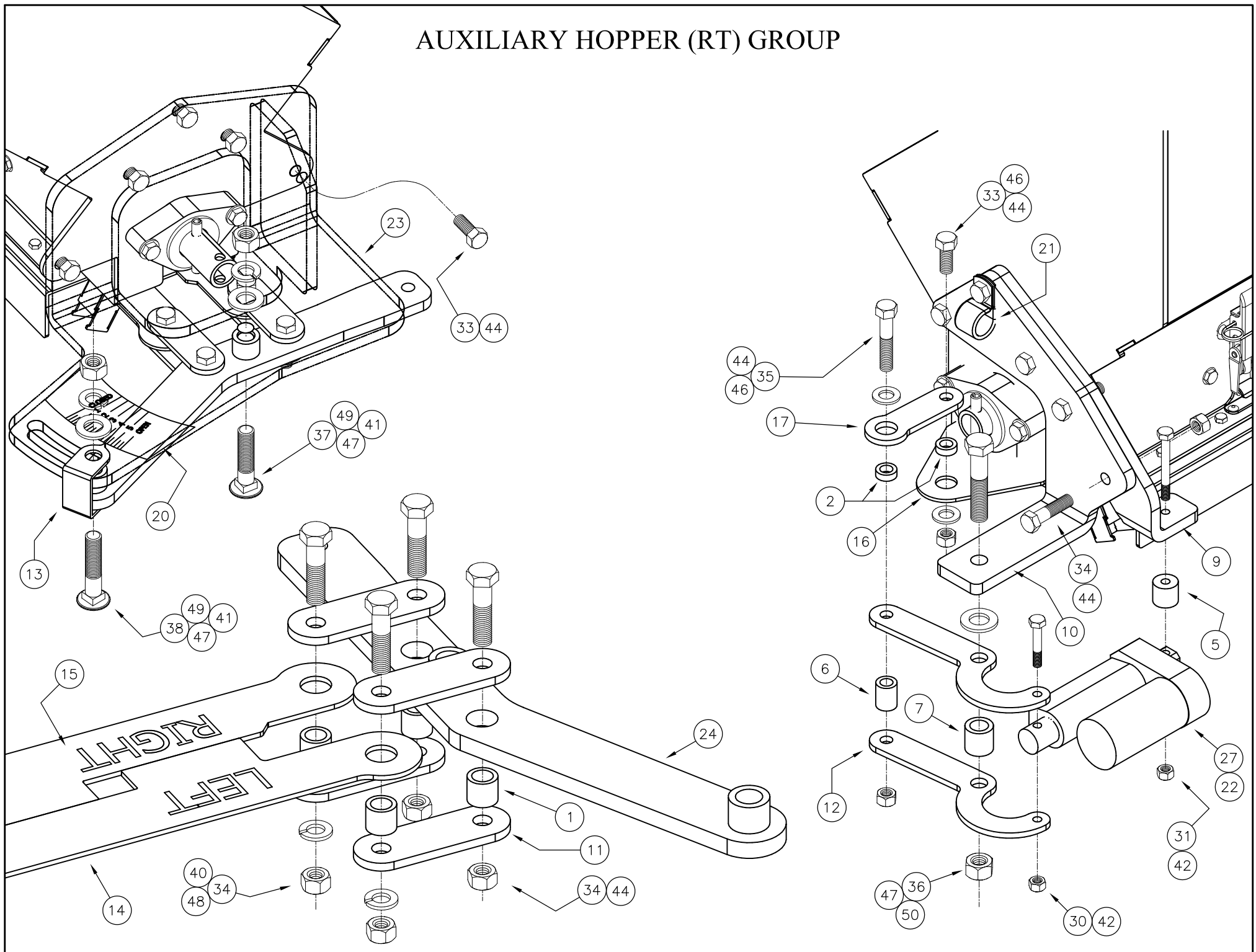

AUXILIARY TO PRIMARY HOPPER GROUP

ITEM	PART NO	DESCRIPTION	QTY	ITEM	PART NO	DESCRIPTION	QTY
1	DS26-007	BOX CONNECTOR 12 FT	1	13	ND50-102	1 ID X 1 1/4 OD CLEAR VINYL DS SB	16
2	DS27-036	LEFT SEED PLATE 1/2	2	14	SB50-062	1 3/8 HOSE CLAMP	16
3	DS27-037	RIGHT SEED PLATE 1/2	2	15	DS81-076	AUXILLARY BOX - DS72 HYD.	1
4	DS27-038	LEFT SEED PLATE 3/8	2	16	DS81-031	AUXILLARY BOX - DS72 RT	1
5	DS27-039	RIGHT SEED PLATE 3/8	2	17	HW01010048G5ZPC	5/16 x 1-1/2 HHCS	2
6	ND27-200	DOUBLE BEND HOSE CLAMP	3	18	HW01010064G5ZPC	5/16 x 2 HHCS	1
7	DS50-107	HYD HOSE B	2	19	HW01010080G5ZPC	5/16 x 2-1/2 HHCS	1
8	DS50-108	HYD HOSE C	1	20	HW01010112G5ZPC	5/16 x 3-1/2 HHCS	1
9	DS50-109	HYD HOSE D	1	21	HW24010GBZPC	5/16 STOVER LOCKNUT	5
10	DS50-120	DS HYD. DRIVE FLOW DIVIDER	1	22	HW30010G5ZPC	5/16 FLAT WASHER	5
11	DS50-121	ADAPTER, #8 MJIC x #12 MORB	3				
12	ND50-087	DS-144 SERUAL # TAG	1				

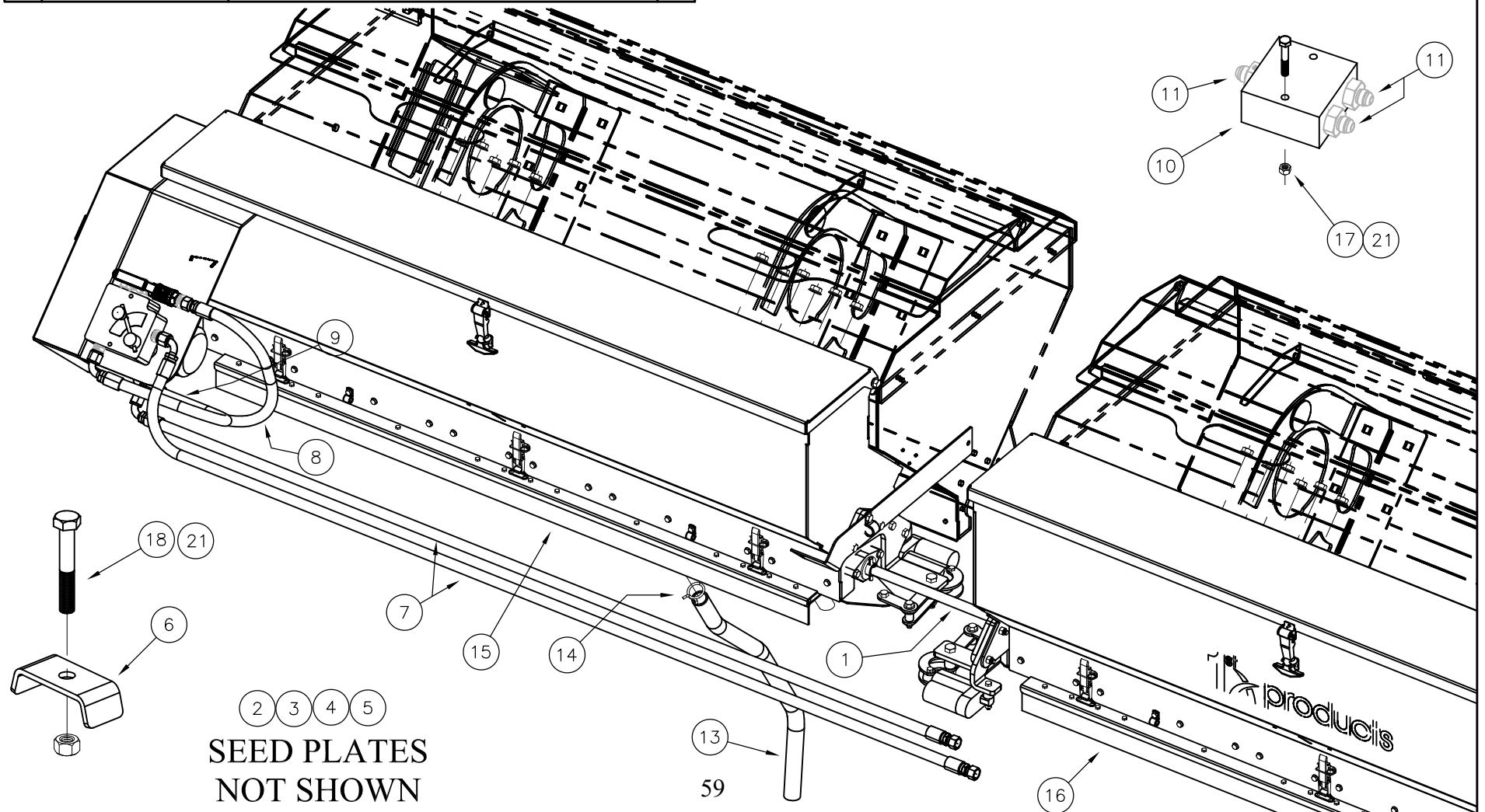

AUXILIARY CHAIN COVER GROUP

ITEM	PART NO	DESCRIPTION	QTY
1	DS80-086	DS CHAIN COVER - AUX. HYD.	1
2	ND50-155	TRIM - DS HYD. AUX. CHAIN GAURD	1
3	SB50-094	SCRATCH COVER	2

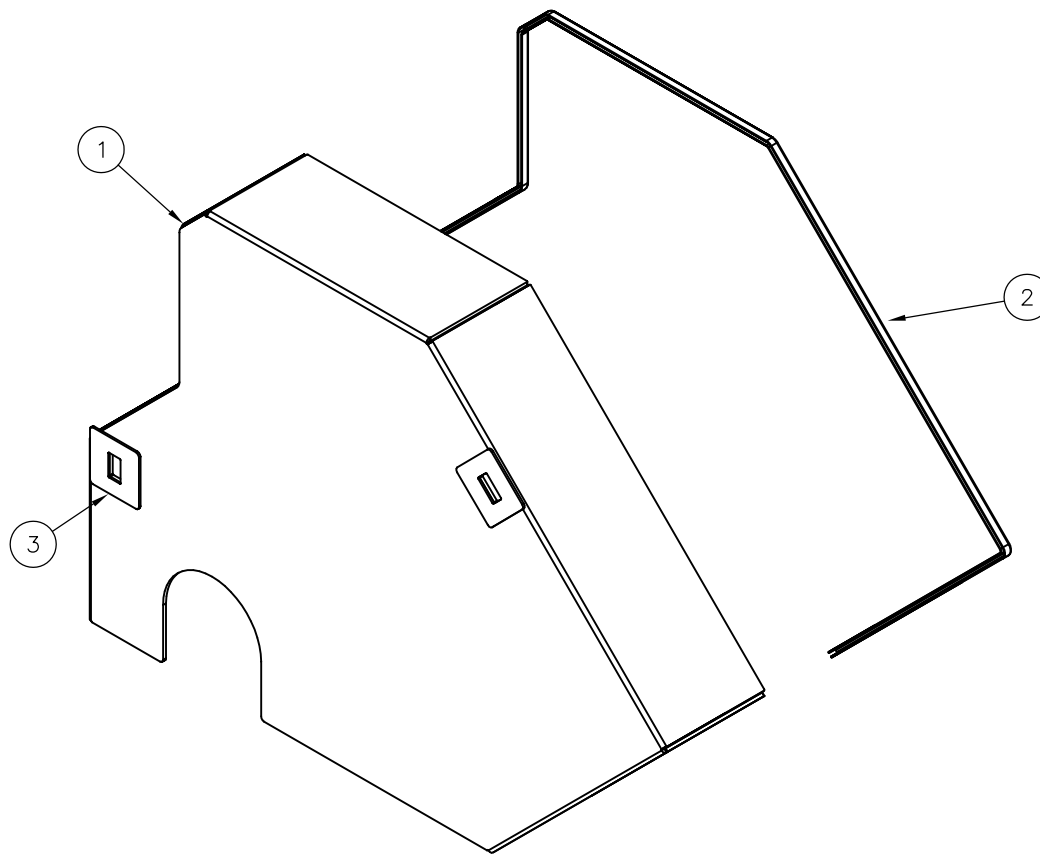

ELECTRICAL GROUP

ITEM	PART NO	DESCRIPTION	QTY	ITEM	PART NO	DESCRIPTION	QTY
1	AE50-279	1/4 MALE PUSH ON INSULATED TERMINAL	1	16	DS50-114	RED INDICATOR LIGHT	2
2	DS27-266	ACTUATOR SWITCH PLATE	1	17	DS50-115	1/4 MALE FULLY INSUL QUICK-DISCONNECT TERMINAL	2
3	DS50-013	ACTUATOR HARNESS, BOX 1	1	18	DS50-116	ACTUATOR SWITCH BOX ENCLOSURE	1
4	DS50-015	CABLE GLAND	2	19	WB50-083	SWITCH, 2 POS. ON-OFF	2
5	DS50-016	CONTROL BOX POWER IN HARNESS	1	20	DS50-117	7-1/2 AMP MINI FUSE	1
6	DS50-017	CONTROL BOX SWITH HARNESS	1	21	HW16M4008G5ZPC	M4 X 8 MM CROSS HEAD SCREW	2
7	DS50-018	ACTUATOR HARNESS, BOX 2	1	22	DS50-123	RELAY POWER WIRE	1
8	DS50-023	FUSE LINK	1	23	AE50-129	2-7/8 TEST CLIP	2
9	DS50-029	22-14 GA 3 COND PIGTAIL CONNECTOR	3	24	AE50-130	RED INSULATOR	1
10	DS50-033	RELAY GROUND WIRE ASSM	1	25	AE50-131	BLACK INSULATOR	1
11	DS50-074	RELAY, DPDT	2	26	DS50-046	POWER HARNESS W/ TEST CLIPS	1
12	DS50-076	GLAND NUT	2	27	ND50-095	PIERCE ON/OFF SWITCH	1
13	DS50-111	ACTUATOR SWITCH POWER WIRE	1	28	ND50-100	ON/OFF DECAL	1
14	DS50-112	ACTUATOR RELAY POWER WIRE BOX 1	1				
15	DS50-113	ACTUATOR RELAY POWER WIRE BOX 2	1				

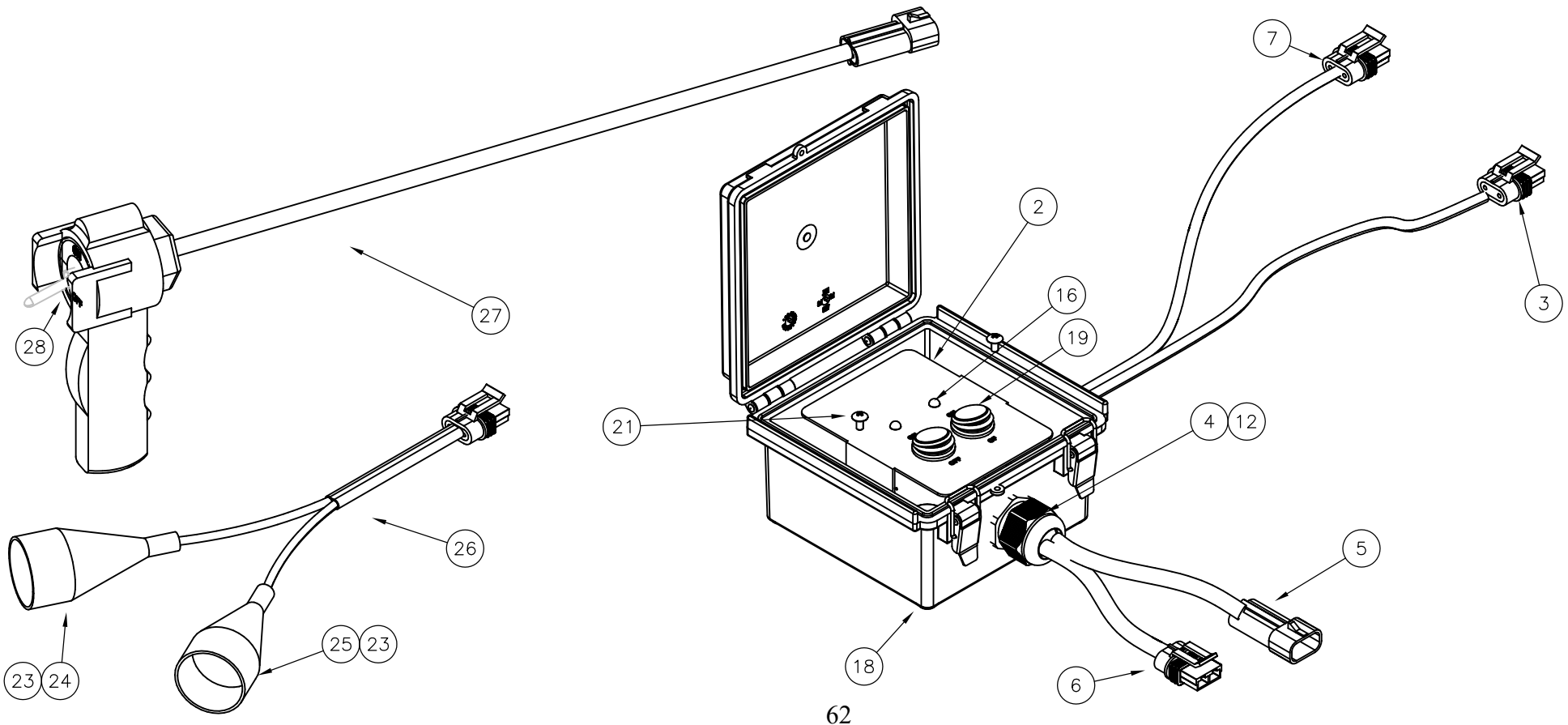

ELECTRICAL GROUP

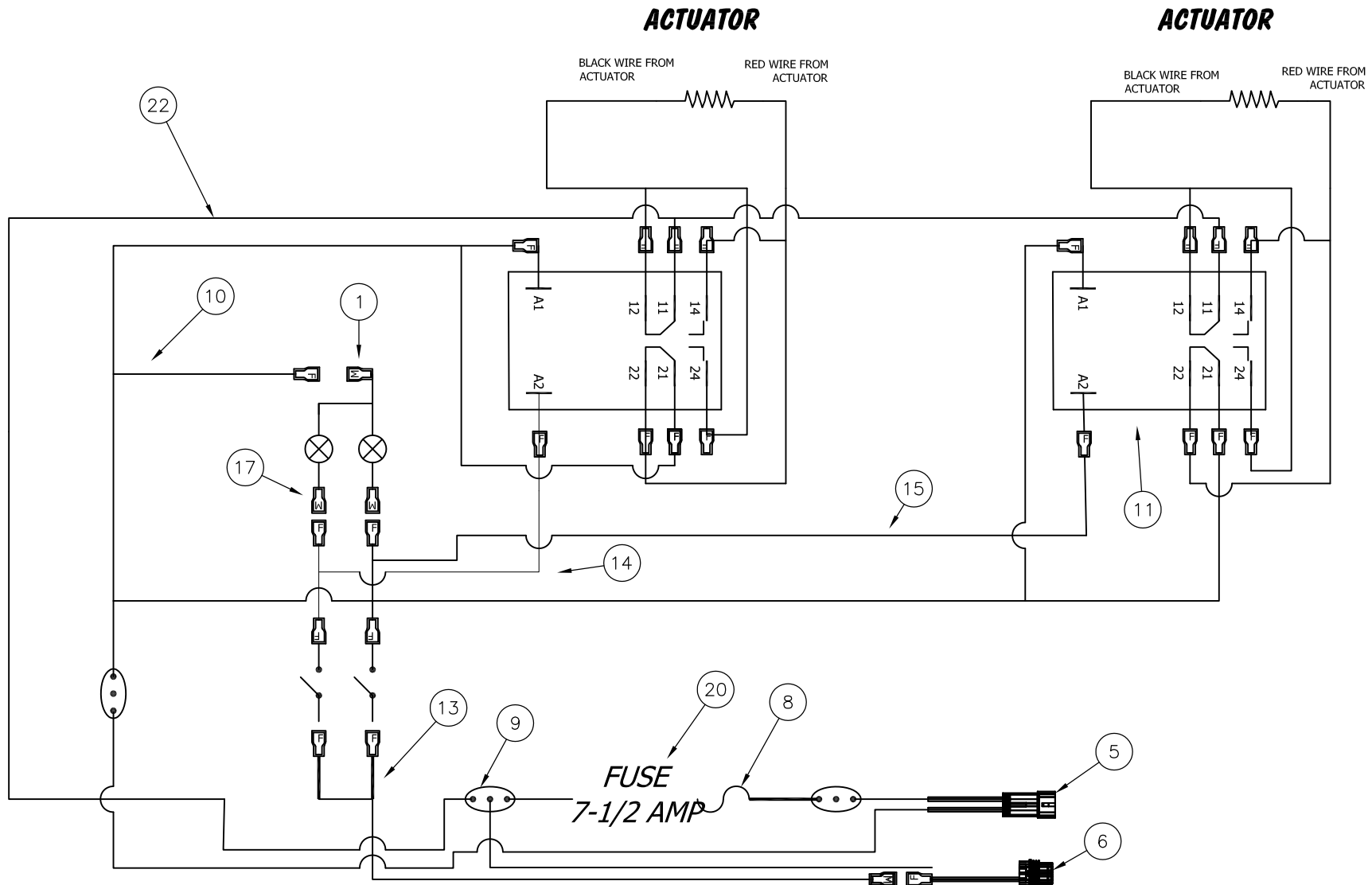

TOW HITCH GROUP

ITEM	PART NO	DESCRIPTION	QTY	ITEM	PART NO	DESCRIPTION	QTY	ITEM	PART NO	DESCRIPTION	QTY
1	DS50-051	3/4" ID LOOP CLAMP	3	14	ND27-162	5/8 HOSE CLAMP BOTTOM	4	27	ND50-125	HOSE, LFPH LT	2
2	DS50-093	LFPH EXTENSION HARNESS	1	15	ND27-163	5/8 HOSE CLAMP TOP	4	28	ND50-126	HOSE, LFPH RT	2
3	FA50-068	QUICK COUPLER, MALE	2	16	ND50-026	ADJUSTABLE CLEVIS	1	29	ND50-127	SAFTEY CHAIN	1
4	FA50-107	CYLINDER, 3" x 18"	2	17	ND50-027	5000LB TUBE MT. TOPWIND JACK	1	30	ND50-128	SAFTEY CHAIN CLEVIS HOOK	2
5	HW01008112G5ZPC	1/4 x 3-1/2 HHCS	2	18	ND50-114	INTEGRATED FLOW DIVIDER AND PTOC	1	31	ND50-134	ADAPTER, ORFICE 0.070	2
6	HW01012128G5ZPC	3/8 x 4 G5HHCS	2	19	ND50-116	TWIN TUBE CLAMP .625" OD	3	32	ND80-058	LARGE FRAME PULL HITCH CAT. 3N	1
7	HW01020176G8ZPC	5/8 x 5-1/2 G8 HHCS	4	20	ND50-118	LFPH STOP PIN 3.625" USEABLE	2	33	ND81-068	1.5" ROD DEPTH STOP ASSM.	2
8	HW20020G5ZPC	5/8" HEX NUT	4	21	ND50-119	CAT. 3 TOP LINK PIN	1	34	SE50-035	7/16 LYNCH PIN	3
9	HW24008G5ZPC	1/4" STOVER LOCK NUT	2	22	ND50-120	CAT. 3 TO 2 TOP LINK REDUCER	1	35	VC50-060	3/8 X 2 1/2 SWLP	4
10	HW24012G5ZPC	3/8" STOVER LOCK NUT	2	23	ND50-121	CAT. 3 TOP LINK	1	36	WB50-029	ADAPTER, STRAIGHT #6MJIC-#6MORB	3
11	HW31008TAZP	1/4" SAE FLAT WASHER	2	24	ND50-122	1" HITCH PIN RED HANDLE	1	37	WB50-031	ADAPTER, 90 DEG #6MJIC-#6MORB	1
12	HW33020G8ZPC	5/8" X.H.D. LOCK WASHER	4	25	ND50-123	ADAPTER, 90 DEG #6MJIC-#8MORB	4	38			1
13	ND27-161	SAFTEY STOP	2	26	ND50-124	HOSE, LFPH PRESSURE/RETURN	2				

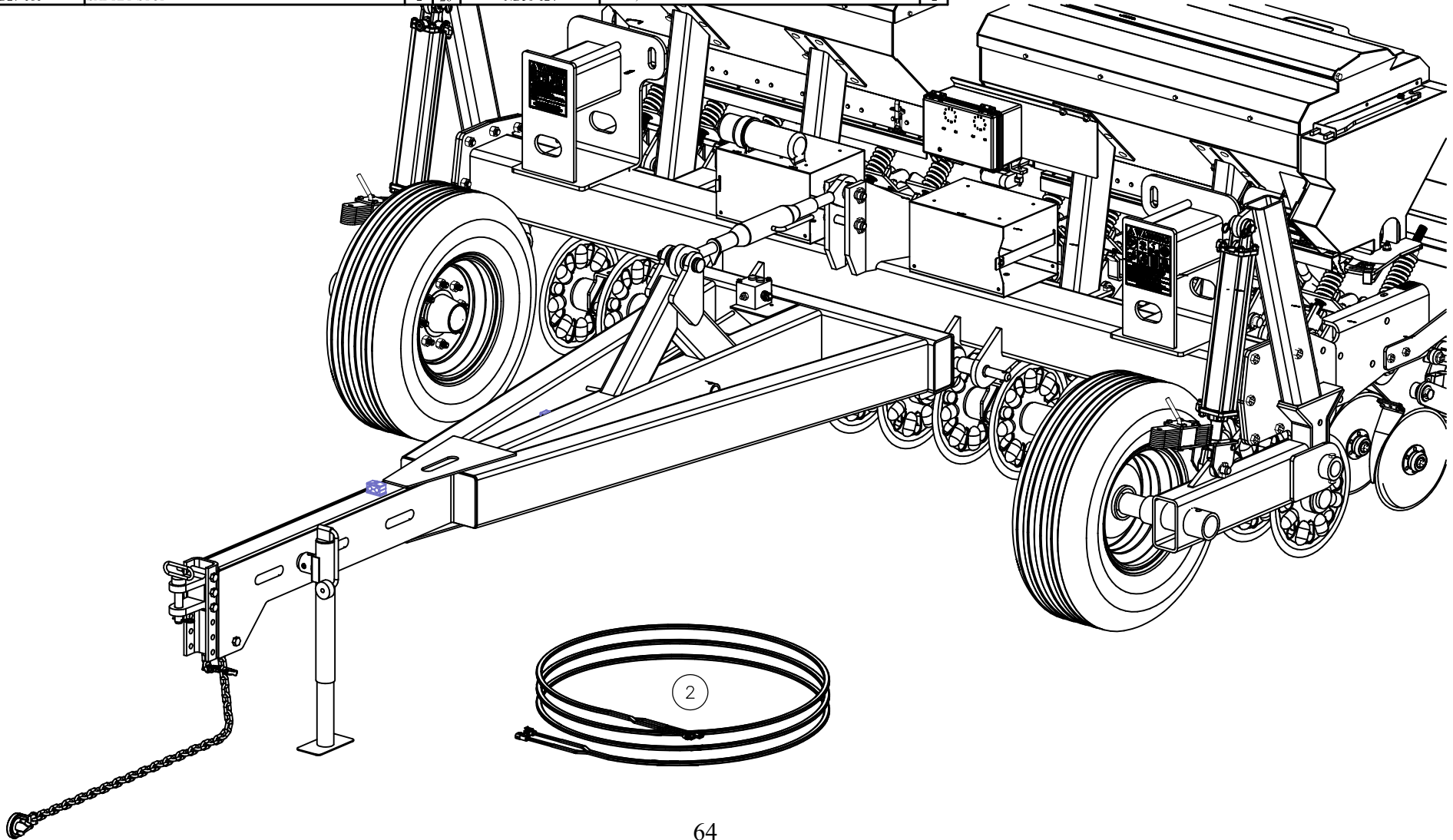

TOW HITCH GROUP

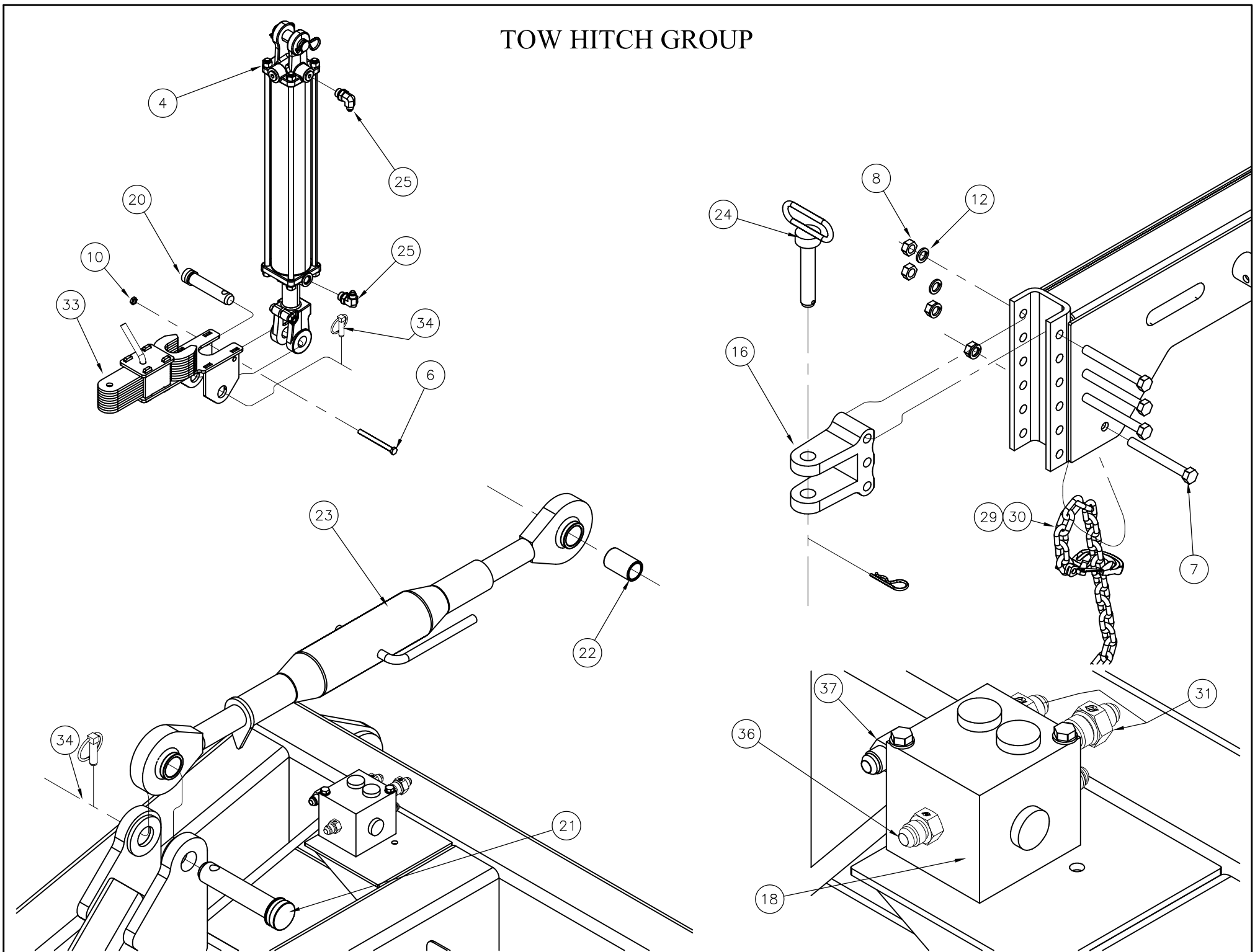

TOW HITCH GROUP

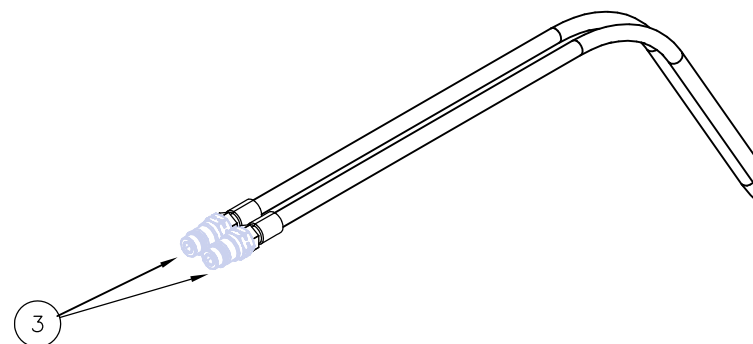
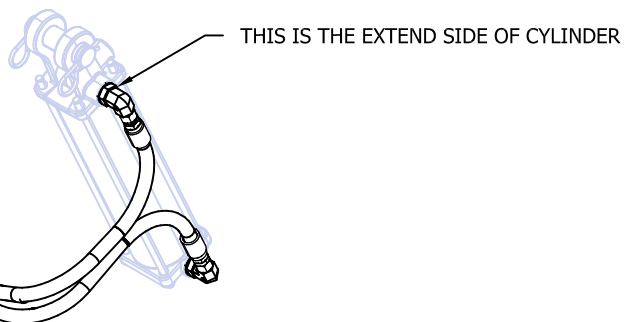

THESE PORTS ARE FOR THE RIGHT SIDE HYDRAULIC CULINDER, THE OTHER TWO ARE FOR THE LEFT SIDE CYLINDER

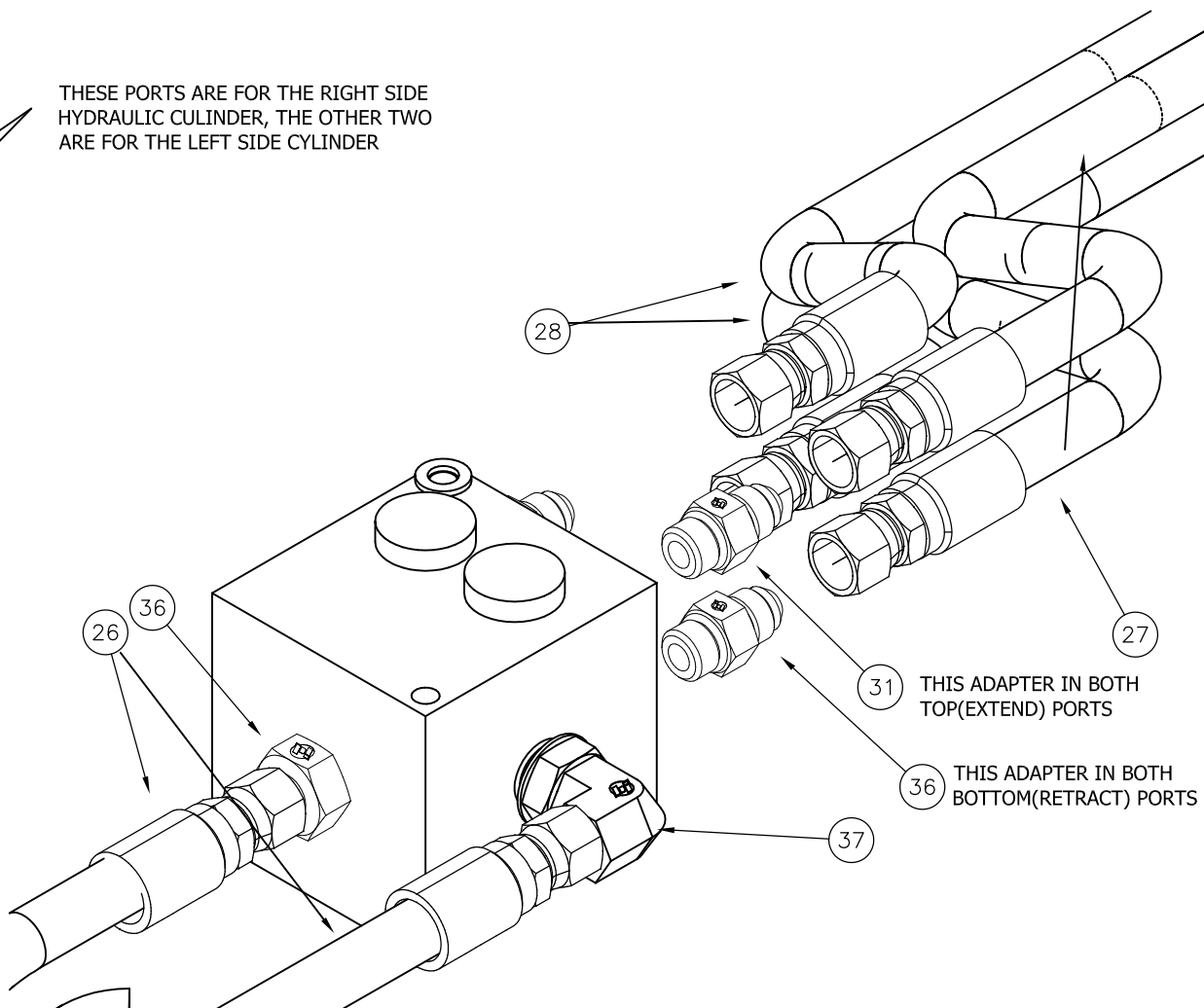
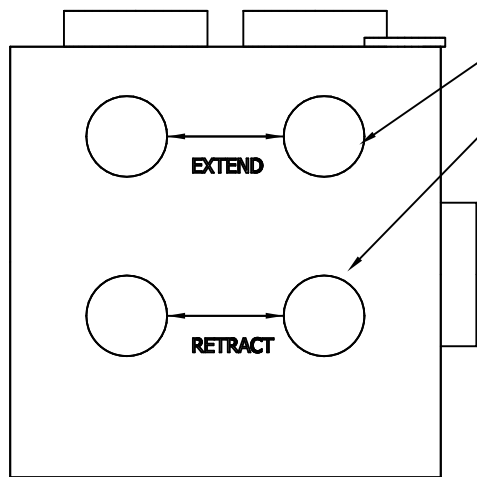

BOLT TORQUE SPECIFICATIONS

COURSE

FINE

DIAMETER	THD/INCH	GRADE 2	GRADE 5	GRADE 8
1/4	20	37 IN-LBS	86 IN-LBS	122 IN-LBS
5/16	18	75	178	251
3/8	16	11 FT-LBS	26 FT-LBS	37 FT-LBS
7/16	14	18	42	59
1/2	13	27	64	90
9/16	12	39	92	130
5/8	11	54	128	180
3/4	10	96	227	320
7/8	9	155	365	515
1	8	232	547	772
1 1/4	7	463	952	1545
1 1/2	6	806	1657	2688
1/4	28	42 IN-LBS	99 IN-LBS	139 IN-LBS
5/16	24	83	197	278
3/8	24	13 FT-LBS	30 FT-LBS	42 FT-LBS
7/16	20	20	47	66
1/2	20	31	72	102
9/16	18	44	103	146
5/8	18	61	144	204
3/4	16	107	253	357
7/8	14	171	403	568
1	14	260	614	867
1 1/4	12	513	1055	1710
1 1/2	12	907	1865	3024